

# CERTA

## Certified Roofing Torch Applicator Program



## Torch-applied Roof System Safety Student Manual



**NRCA**

National Roofing Contractors Association  
10255 W. Higgins Road, Suite 600  
Rosemont, IL 60018-5607  
(847) 299-9070  
Fax: (847) 299-1183  
E-mail: [nrca@nrca.net](mailto:nrca@nrca.net)  
[www.nrca.net](http://www.nrca.net)



Midwest Roofing Contractors Association  
4700 W. Lake Ave.  
Glenview, IL 60025  
(847) 375-4748  
Fax: (847) 375-6475  
E-mail: [mrca@mrca.org](mailto:mrca@mrca.org)  
[www.mrca.org](http://www.mrca.org)

Published by the National Roofing Contractors Association and Midwest Roofing Contractors Association

©2010 by the National Roofing Contractors Association and Midwest Roofing Contractors Association  
All rights reserved  
Published 2010  
Printed in the United States of America

No part of this publication may be reproduced or distributed in any form or by any means or stored in a database or retrieval system without prior written permission of the publishers.

# **Certified Roofing Torch Applicator Program**

## **Torch-applied Roof System Safety**

---

### Student Manual

# Table of Contents

## Preface

Certified Roofing Torch Applicator Program .....i  
 Foreword .....ii  
 Purpose .....ii

## Introduction

Program Description .....1  
 Key Learning Objectives .....2  
 New Industry Safety Practices .....2  
 My Favorite T-shirt .....5

## Section 1: General Requirements

Training .....7  
 Personal Protective Equipment .....7  
 First Aid .....7  
 Fire Safety .....9  
 Fire Safety Tick-tack-toe .....17

## Section 2: Pre-job Planning and Preparation

Pre-job Inspections and Checklist .....18  
 Identifying Hazards and Preventive Measures .....18  
 Job-site Hazards and Controls Matching .....23

## Section 3: Propane Tool and Equipment Safety

Propane Gas Characteristics .....24  
 Torch Assemblies .....24  
 Propane Cylinders and Valves .....26

## Section 4: Application Safety

Membrane Application .....31  
 Torch Equipment Operation .....31  
 Safe Torch Application Techniques .....33  
 Application Hazard Recognition .....38  
 Assembling a Roofing Torch Assembly .....46

## Section 5: Post-job Requirements and Duties

Post-job Fire Watch .....47  
 Other Post-job Requirements and Duties .....49  
 Ten Fire-watch and Post-job Basics .....50

## Appendix: Reference Materials

Related Industry Organizations .....51  
 Glossary .....52  
 Determining Propane Vaporization Capacities .....54  
 Daily Inspection Checklist .....55  
 Hands-on Performance Evaluation Form .....59  
 Training Evaluation Form .....61

# PREFACE

---

## **Certified Roofing Torch Applicator Program**

### **NATIONAL ROOFING CONTRACTORS ASSOCIATION**

10255 W. Higgins Road, Suite 600  
Rosemont, IL 60018-5607  
(847) 299-9070  
Fax: (847) 299-1183

### **MIDWEST ROOFING CONTRACTORS ASSOCIATION**

4700 W. Lake Ave.  
Glenview, IL 60025  
(847) 375-4748  
Fax: (847) 375-6475  
E-mail: [mrca@mrca.org](mailto:mrca@mrca.org)  
[www.mrca.org](http://www.mrca.org)

## **Acknowledgement**

NRCA and MRCA thank the dedicated roofing industry professionals who volunteer to serve on the joint CERTA Task Force to oversee and maintain the CERTA program.

## Foreword

Congratulations! Participating in the Certified Roofing Torch Applicator (CERTA) Program demonstrates you are committed to improving your personal safety and the safety of your co-workers. You also are elevating the professionalism of the entire roofing industry. This training program is designed to familiarize you with safety issues and concerns relating to the application of torch-applied roof systems and to directly affect your habits and behaviors during application.

Torch-applied roof systems have been an important part of the roofing industry since the 1970s. Although safety concerns for torch-applied systems have been addressed in the past, personal injuries and property damage still occur. Whether for patchwork or installing a new roof system, most roofing workers use a torch at one time or another. However, many roofing workers have never received proper torch safety training. The results: Major fires, severe injuries and deaths have occurred because of careless roofing torch use.

This manual cannot replace experience and should not be a substitute for a company's written safety program. There also are state Occupational Safety and Health Administration regulations and local fire and building code requirements that are unique to your area and may not be included in this program.

This training program manual is designed to promote safety in the application of torch-applied roof systems. It is intended for use by anyone with an interest in these systems, from managers and supervisors to foremen and roofing workers. It is a culmination of efforts by contractors, manufacturers, suppliers and others who are dedicated to promoting safety.

Always keep in mind that roofing is what we do, and safely is how we do it!

## Purpose

The purpose of the CERTA program is to provide roofing professionals with the necessary safety training to enhance professionalism and reduce personal injuries and property losses caused by the use of roofing torches.

# INTRODUCTION

In 1986, the Midwest Roofing Contractors Association (MRCA), in conjunction with the Asphalt Roofing Manufacturers Association and the United Union of Roofers, Waterproofers and Allied Workers, developed a curriculum for training roofing workers in the safe application of torch-applied roof systems. This program was named the Certified Roofing Torch Applicator Program, or CERTA.

In 2003, the insurance industry approached NRCA to address concerns about increasing incidents and losses occurring during torching activities by roofing contractors. NRCA recognizes torching activities are and will continue to be a major part of the roofing industry, and roofing workers traditionally have been trained in torch use using on-the-job techniques. This training method typically has not addressed safety concerns; thus, the need became apparent for focused safety training in torching activities. NRCA has arranged with MRCA to adopt and revise the CERTA program to meet this industry need.

This updated CERTA program provides the latest safety practices and new industry requirements for torching activities. CERTA delivers these requirements through the combined use of this student manual, video instruction and a hands-on training class. There is no comparable safety training program available in the roofing industry.

Safety is the cornerstone of success for any roof system installation. The CERTA program is designed to provide safety training for roofing professionals at all levels. This certification program comprises standards and safety practices that companies can use to implement and expand their safety programs.

## Program Description

The CERTA program addresses the safety concerns of roofing contractors, the insurance industry, fire and code authorities, roofing material manufacturers, equipment manufacturers and fuel suppliers.

Upon successful completion of the training program, you will be certified as a Certified Roofing Torch Applicator. A CERTA identification card will be issued to you, and a list of certified applicators' names will be maintained in a secure database.

This certification will remain valid for three years. It may be rescinded if you are observed performing unsafe work practices or behaviors. Certain recertification conditions and additional training and testing will be required at the end of the three-year period for you to maintain certification.

## Recertification

A written notice will be mailed to you a minimum of six months prior to your certification expiration date providing detailed information, requirements and procedure instructions to recertify. Additional notices will be mailed three months prior and one month prior to the expiration date. Each notice will be mailed to the address provided at the time of your certification. The CERTA program administrator will not attempt to contact applicators whose notifications are returned as undeliverable. It is your responsibility to directly inform the CERTA program administrator of changes to your contact information.

## Program Success

The number of serious roofing torch-related fire incidents has decreased significantly since 2004 when the new CERTA program was implemented in the roofing industry. The following data regarding losses paid for fire damage caused by improper use of a roofing torch were shared by one major U.S. insurance underwriter that offers general liability coverage to roofing contractors.

Loss Year	Number of Claims	Loss Amount
2002	46	\$13,784,800
2003	23	\$7,822,500
2004	20	\$3,901,000
2005	13	\$3,717,500
2006	14	\$1,583,500
2007	10	\$287,800

The new CERTA program has had a significant effect on the safe use of roofing torches throughout the roofing industry.

## Key Learning Objectives

Upon completion of the CERTA training, you will be able to:

- List personal protective equipment (PPE) requirements for torching activities
- Describe basic first-aid procedures associated with torching activities
- Explain proper steps and procedures for handling propane gas cylinders
- Identify components of a torch assembly
- Demonstrate safe assembly, lighting and use of torch equipment
- Identify the key elements of a comprehensive pre-job inspection
- Recognize hazardous areas
- Prescribe hazard controls when torching near hazardous areas
- Demonstrate safe torching techniques near hazardous areas
- Explain post-job fire watch and other duties

In addition to accomplishing these objectives, this program provides information and reference resources that complement various topics addressed in this training. This information can be applied to all roofing work and used to enhance a company's safety program.

## New Industry Safety Practices

The following outline of recent industry changes was compiled by NRCA in collaboration with the insurance industry. All of these new safety practices have been incorporated into this training program. Reviewing the list now will help you relate to specific topics during training.

### CERTA Safety Practices for Roofing Torch Use

#### 1. CHECKLIST

- 1.1 Complete the daily checklist for all torching jobs.

#### 2. PRE-JOB PLANNING

- 2.1 Identify and protect plywood, oriented strand board (OSB), wood plank, wood fiberboard and other combustible building components as follows:
  - 2.1.1 The job foreman or supervisor shall review daily with the building owner conditions that could present hazards during torching and address them.
  - 2.1.2 Address possible fire traps and hidden hazards; see No. 3, Torching Safety, Items 3.1 through 3.5.
- 2.2 Have a minimum of two 4A60BC fire extinguishers available within 10 feet of torch operations.
- 2.3 Train all personnel on the roof on how to use a fire extinguisher.
- 2.4 Inspect penetrations, such as exhaust vents, inside and outside. Lint, grease or other substances, if present, shall be cleaned prior to torching work.
- 2.5 Have a cell phone available or other means of communicating with 911 or another emergency responder.
- 2.6 Comply with state and local ordinances where applicable.

- 2.7 Field-of-the-roof installation
- 2.7.1 Over *combustible*<sup>1</sup> roof decks:
- 2.7.1.1 A thermal barrier shall be incorporated into the roof system design using torch-applied polymer-modified bitumen sheet products. Acceptable thermal barriers include one of the following:
- Minimum ¾-inch-thick perlite board insulation
  - Minimum ¾-inch-thick fiberglass board insulation
  - Minimum ¼-inch-thick gypsum roof board
- 2.7.1.2 When a thermal barrier is installed, comply with the manufacturer’s recommendations and the recommendations contained in The NRCA Roofing Manual.
- 2.7.2 Over *noncombustible*<sup>2</sup> roof decks:
- 2.7.2.1 Comply with the manufacturer’s recommendations and the recommendations contained in The NRCA Roofing Manual.
- 2.8 Flashing installation: Polymer-modified bitumen flashings shall be installed using one of the following flashing system application methods:
- 2.8.1 Torch-and-flop indirect torching
- 2.8.2 Cold-applied adhesives
- 2.8.3 Mop-applied with hot bitumen
- 2.8.4 Direct torching using a single-burner, low-output (105k Btu or less) “detail” torch over *combustible*<sup>1</sup> or *noncombustible*<sup>2</sup> substrates as follows:
- 2.8.4.1 Over *combustible*<sup>1</sup> substrates, an air-impermeable backer layer with sealed laps installed over the flashing substrate shall be incorporated into the flashing assembly prior to the application of the torch-applied polymer-modified bitumen sheet finish surface. Acceptable adhered backer layers include one of the following:
- A layer of fiberglass ply sheet, fiberglass base sheet or polymer-modified bitumen base sheet mechanically fastened to the substrate and an additional layer of a minimum of one layer fiberglass ply sheet or polymer-modified bitumen base sheet adhered to the underlying layer in solid moppings of hot asphalt
  - Minimum of one layer of self-adhering, smooth-surfaced polymer-modified bitumen sheet
- 2.8.4.2 Over *noncombustible*<sup>2</sup> substrates, an adhered backer layer with sealed laps installed over the flashing substrate shall be made part of the membrane flashing assembly prior to the application of the torch-applied polymer-modified bitumen sheet finish surface. Acceptable adhered backer plies include one of the following:
- Minimum of one layer of fiberglass ply sheet, fiberglass base sheet or polymer-modified bitumen base sheet adhered in solid moppings of hot asphalt
  - Minimum of one layer of self-adhering, smooth-surfaced polymer-modified bitumen sheet
- Note: If the membrane flashing substrate cannot be specifically identified as *noncombustible*,<sup>2</sup> direct torching with a detail torch is permitted if 2.8.4.1 is used.

### 3. TORCHING SAFETY

- 3.1 Only CERTA certified torch applicators shall operate torches when an open flame will contact any part of a roof.
- 3.1.1 Using an open flame for roof drying or de-icing over *combustible*<sup>1</sup> roof surfaces shall not be permitted.
- 3.1.2 The use of an open flame torch solely to heat bitumen equipment valves (i.e., hot luggers, felt layers or kettles) or bitumen pipe assemblies is acceptable and may be performed by a noncertified applicator as long as an open flame does not contact *combustible*<sup>1</sup> roofing materials.

- 3.2 Protect materials that may burn when in contact with an open flame. Never torch directly to any *combustible*<sup>1</sup> material.
- 3.3 Never torch directly in an area where you cannot see the path of the open flame (including—but not limited to—flashings, corners, curbs, voids, expansion joints and small roof penetrations). Use alternative application methods, such as torch-and-flop indirect torching, cold-applied adhesives or mop-applied with hot bitumen, in these areas.
- 3.4 A lit torch shall only be placed on the roof surface using a functional torch stand.
- 3.5 A lit torch shall never be left unattended.

#### 4. END-OF-DAY FIRE WATCH

- 4.1 A minimum two-hour fire watch, as described in the new CERTA training program, shall be conducted by a properly trained and dedicated individual; it shall include checking the roof's underside for smoldering (whenever possible), as well as the top side.

<sup>1</sup> *combustible*, i.e., plywood, OSB, wood plank or wood fiberboard

<sup>2</sup> *noncombustible*, i.e., concrete, masonry, concrete block or gypsum

## My Favorite T-shirt

### Instructions

Think of a favorite T-shirt you own or would like to have made for you. What would it look like? What would it say? In the lines below, write down a description of this T-shirt and explain how it represents your personality. Examples might include a T-shirt with a picture or logo of your favorite band, a souvenir T-shirt from one of your vacations or a Harley-Davidson motorcycle T-shirt. Your instructor may ask you to share this with the rest of the class.

---

---

---

---

---

Turn the page and illustrate your idea (optional).

### My Favorite T-shirt

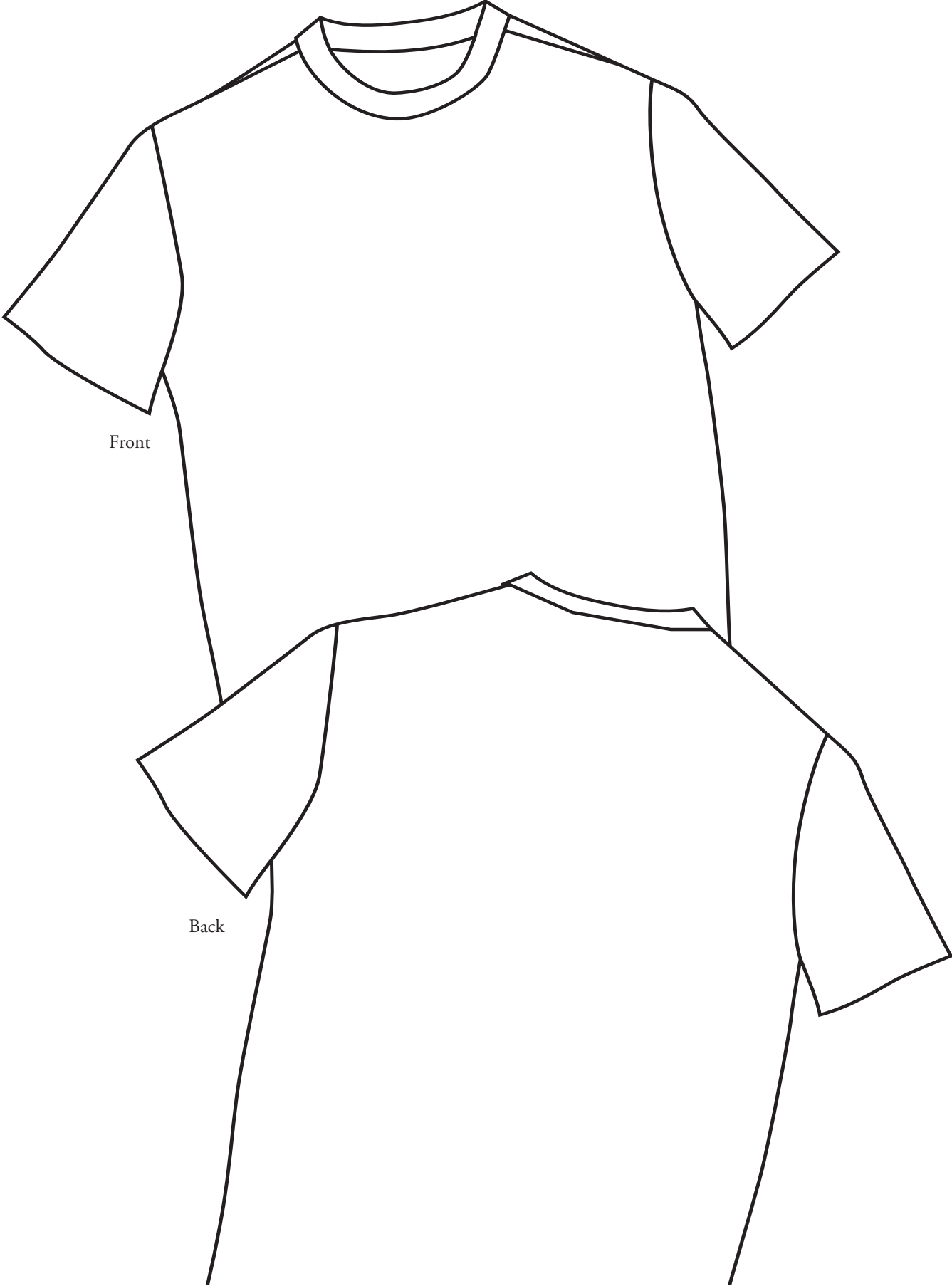

## Section

## 1

## GENERAL REQUIREMENTS

## Training

Safety is everyone's responsibility. All participants involved with a roofing project need to have a thorough understanding and keen awareness of specific safety issues involved with creating and maintaining a safe roofing workplace. Safety training not only is important, but it also is a requirement before taking your first step onto a roofing job. Sharing safety information is important in creating a safe work environment. If you are not sure about something relating to your work, be sure to ask your foreman or supervisor. There are no dumb questions when it comes to protecting yourself, crew members, building occupants and the building itself. In fact, you will earn respect when people realize you care about safety. Take time to find out about anything you don't know!

## Personal Protective Equipment

All crew members should wear proper personal protective equipment, or PPE. Let's start with clothing, goggles and hard hats, your body's first line of defense.

- Remove all rings and other jewelry before you start work.
- Wear long-sleeved shirts buttoned at the cuffs. Shirts should be made of cotton, wool or some other nonflammable material. Don't wear polyester because if exposed to flame, polyester can melt into the skin and cause severe and painful burns (see Photo 1).
- Make sure your work boots cover your ankles and have rubber or composite soles.
- Wear pants, without cuffs, that extend over the tops of your work boots (see Photo 2).
- Wear heavy leather gloves whenever you have a torch in your hand. Better yet, flame-retardant gauntlets are recommended in addition to your gloves and long-sleeved shirt (see Photo 3).
- Wear goggles or a face shield to protect your face and eyes from flames. Flames have a way of flaring up when confined to tight spaces. Eye and face protection should conform to ANSI Z87 (see Photo 3).
- Always wear hard hats when there are overhead hazards. Hard hats should meet ANSI Z91 specifications.



Photo 1: Severe burns are painful.



Photo 2: Pants should extend over the tops of boots.



Photo 3: Flame-retardant gauntlets and face shield

## First Aid

### First Aid for Heat-related Illnesses and Heat-stress Disorders

Torching can be hot work. Torch-head temperatures can reach 2,000 F, and the additional heat generated by a torch on a hot day may make you uncomfortable or sick. Besides being uncomfortable in a hot environment, you may not be able to focus well on your surroundings, and your attention may be easily diverted. Dizziness, poor judgment and slow reaction times all can occur if you are overheated. All these indirect hazards are just as dangerous as the obvious hazards associated with roofing work. Working in hot conditions also can create other hazards. For example, sweat in your eyes and slippery hands can be aggravating and cause problems with work performance.

#### *Heat-stress Symptoms*

You also should know a few facts about heat stress disorders and the precautions to take to avoid them. Think about how you will recognize these symptoms in yourself and others when you are working in extremely hot conditions.

Mild symptoms include:

- Muscle spasms
- Heavy sweating
- Fatigue
- *Normal* body temperature

Serious symptoms (heat exhaustion) include:

- Cool, wet, pale skin
- Weakness
- Mental confusion
- Nausea or vomiting
- Headache
- *Normal or slightly above normal* body temperature

Life-threatening (heat stroke) symptoms include:

- Sweating stops
- Red, dry skin
- Rapid pulse
- *Rapidly rising* body temperature (105 F or more)

### ***What To Do***

If you have any of these heat-stress symptoms, stop working immediately. Seek either a cool, shaded area or an air-conditioned location, and drink moderate amounts of nonalcoholic/noncaffeinated liquids. If serious or life-threatening symptoms occur, immediately seek emergency medical attention.

### ***Heat-related Illness Preventive Measures***

You can help prevent heat-related illnesses during prolonged sun exposure by following these guidelines:

- Wear light-colored cotton clothing.
- Wear a hat to protect your head and eyes.
- Allow your body to acclimate to hot conditions before working full days in extreme heat.
- Drink plenty of *nonalcoholic/noncaffeinated* liquids before, during and after work.
- Get out of the sun whenever possible to break up long periods of exposure.

### **First Aid for Burns**

First-degree burns are caused by sun, scalding by steam or brief contact with hot objects such as torch heads. First-degree burns will make the skin red, warm and sensitive to touch. You can help relieve pain by applying cool water or submerging the burned area in cool water.

Do not apply any ointments, fats or oils. See a doctor if a first-degree burn is extensive or swelling occurs.

Second-degree burns result from serious sunburn, contact with hot liquids (such as hot polymer-modified bitumen), flash burns from gasoline, open flame from torches and many other sources. You should seek medical treatment for all but the smallest second-degree burns.

### ***Do not do any of the following:***

- Break blisters

- Apply antiseptics, ointments, sprays or home remedies on severe burns
- Remove any kind of bitumen that is stuck to the skin

Pain can be relieved temporarily by excluding air from the wound. Three ways to do this are:

- Submerge the area in cool water.
- Apply a cool pack (clean cloths that have been wrung out in cool water) to the area.
- Cover the area with a wet dressing and wrap it in plastic to keep moist. If a dressing is allowed to dry, it could stick to the wound and make the injury worse.

Third-degree burns are caused by direct flame exposure, ignited clothing, contact with hot objects or hot bitumen, immersion in scalding water or electricity. Skin will appear white or charred. Damage to the body is more severe than with second-degree burns. Do not remove charred clothing or any bitumen that is stuck to the skin. Never apply ointments or commercial burn preparations.

First-aid steps:

- Immediately call for an ambulance.
- Cover the burned area with clean dressing or cloth.
- If possible, raise the burn area higher than the heart.
- Make sure the victim does not walk around.
- Observe victims with facial burns for breathing problems.
- **Seek immediate medical attention!**

If a victim is unconscious, check for breathing and a heartbeat. If necessary, perform cardiopulmonary resuscitation (CPR) at once.

### **First Aid for Propane Freeze Burn**

Another kind of burn that can occur during torching activities is a propane freeze burn. The National Propane Gas Association (NPGA) provides the following first-aid recommendations:

- Place the worker in a warm area as soon as possible to allow injured areas to warm gradually. If the area warms too rapidly, skin tissue may be further damaged.
- Gently cover or drape injured areas with clean dressing.
- To relieve pain, immerse affected areas in water that is neutral in temperature (72-85 F).
- If possible, have the worker gradually begin to move the injured area.
- Give the worker warm nonalcoholic and noncaffeinated liquid.
- Do not expose injured areas to excess heat or cold, such as heat lamps, hot water, snow or ice.
- **Seek immediate medical attention!**

## **Fire Safety**

This section addresses the proper ways to respond to a fire. You will learn about fire extinguishers and how and when to use them properly. The goal of this program is not to make you a professional firefighter but to equip you with some basic knowledge and skills that can help protect you, your co-workers and the building where you are working. Fire safety begins before the start of daily work on every job involving torches.

### **Fire Facts**

#### *Fire*

Contrary to popular belief, fire does not spread from board to board nor do combustible materials need to touch an open flame

to ignite. Have you ever lit a cigarette by holding the match flame an inch below the cigarette? The heat generated by the match is enough to bring tobacco to its ignition point. The same principle applies to a fire. Hot air mushrooms when it hits a ceiling, then pours through open doorways and engulfs rooms in tremendous heat. If air is hot enough, it can cause other building materials to ignite. Consequently, roof decks, insulation and walls may all burst into flames suddenly in various parts of a building. Your escape margin may be small.

Most roof decks are extremely poor heat conductors. If you suspect a fire is present under a deck and can feel heat, this means there are tremendous temperatures and smoke on the underside of the deck. Evacuate the roof, evacuate the building and then call the fire department. Do not return to a roof until the fire department gives you approval.

### ***Smoke—The Real Killer***

Smoke, not flames, is the most likely killer in a fire. Few people actually burn to death in a fire; a vast majority (as many as 80 percent) of victims are asphyxiated by toxic fumes long before the flames ever touch them. Many corpses are carried from buildings without a burn mark on them.

Smoke actually is a mixture of a dozen or more poisonous gases. Carbon monoxide always is present in large quantities in a fire—a killer you cannot see, smell or taste. A concentration of only 1.26 percent in the air can knock you unconscious after two or three breaths and kill you in two or three minutes.

In addition to carbon monoxide, you must contend with other poisonous gases that, when combined, can kill you. Color and density of smoke is not a reliable way of telling when smoke is most threatening. Thin, slightly gray smoke can be just as deadly as thick, soupy smoke.

Whenever there is smoke there is potential danger, so get off a roof quickly!

## **Fire Department**

The No. 1 rule if you have a fire, no matter how small it may seem or if the crew extinguishes it, is *always call the local fire department immediately.*

Before starting work each day, the foreman should make sure the telephone number of the closest fire department is posted near the roof access point. In the event of an emergency, you and your crew may need to exit the roof quickly, and having the fire department telephone number located near the roof access point can make a big difference.

For many areas throughout the U.S., 911 is the universal emergency telephone number. However, this is not always the case in rural areas. If the telephone number is 911, then that should be posted. If it is not 911, *the number of the closest fire department* must be posted. It also is a good idea to include in the posting the building address where you are working so you can provide the fire department with the exact location. All crew members should be made aware of this posting location and be reminded about it on a daily basis, especially if the location changes during the course of the job.

All crew members should be made aware of the nearest telephone and the exact address and location of the job site. If the crew is relying on a cell phone on a job site, the fire department telephone number should be programmed into the cell phone before the start of work. Make sure the battery is fully charged because the person calling may need to stay on the telephone with the fire department to direct emergency vehicles to the location.

## **Building Owner Communication**

Part of the pre-job communication with a building owner is asking how to sound fire alarms in the building. Pay attention to the location of building fire extinguishers and firefighting equipment. A building owner should make the roofing contractor, foreman or superintendent aware of any flammable or combustible materials stored in the building or anywhere on the property and of exhaust vents or specialized equipment that may emit flammable vapors.

## **Fire Extinguisher Guidelines**

There are a number of rules and guidelines about fire extinguishers that should be followed for all torching activity:

- All fire extinguishers should be fully charged, 4A60BC.
- Each torch operator should have a fire extinguisher within 10 feet of torching work.
- A minimum of two fire extinguishers should be readily available within 10 feet of all torching activities.

- Fire extinguishers should be placed no closer than 10 feet from any propane cylinder.
- A fire extinguisher should be placed near the access to attic areas.
- All fire extinguishers must have a valid, up-to-date inspection tag by an authorized service provider affixed.
- All fire extinguishers must have a plastic seal band in place through the release pin. This ensures the pin has not been previously removed and the extinguisher has not been discharged.
- If a fire extinguisher is discharged for any reason—even partially discharged—it should be removed from the job site until it can be serviced and recharged by an approved service provider.
- Fire extinguishers should be stored in a secure area at the end of each workday.

Other helpful tips:

- Be careful when moving propane hoses so they do not get tangled around or in position to knock over fire extinguishers.
- A plastic 5-gallon pail of water and clean rags can be used to help extinguish small fires. Water-soaked rags and the 5-gallon pail also can be used for first-aid treatments.

## Using a Fire Extinguisher: The **PASS** System

**P**ull out the ring pin while holding the fire extinguisher upright. This will snap the safety seal.



**A**im the hose at the base of the fire. Start upwind, and approach the fire cautiously.

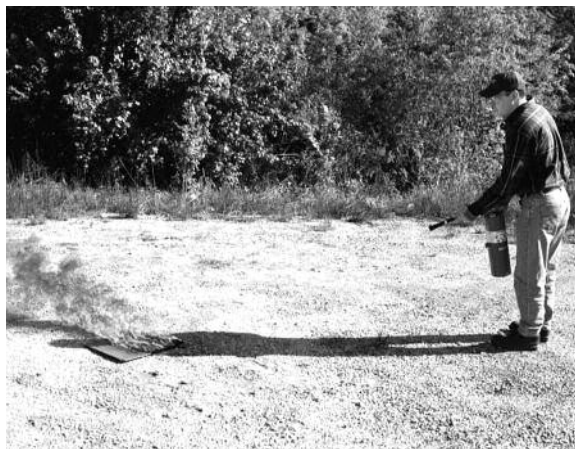

**S**queeze the lever to discharge the extinguisher.



**S**weep the spray from side to side.

**Correct and Incorrect Ways to Extinguish Small Fires**



**Incorrect Way**

This firefighter faces the possibility of facial burns from radiant heat by approaching the fire from downwind and failing to take advantage of the heat-shielding effect of the fire-extinguishing dry chemical.

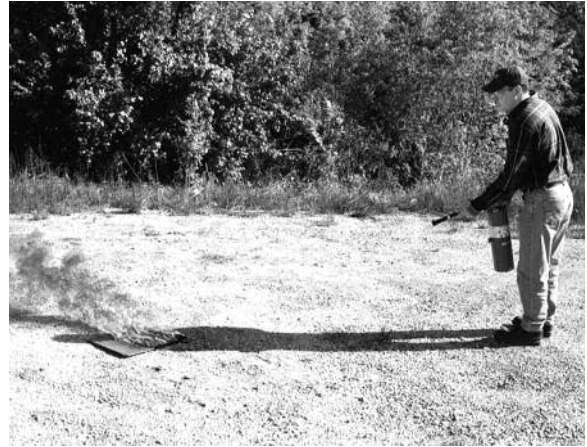

**Correct Way**

Proper application of the dry chemical proves so effective in fighting a small propane fire that the firefighter is able to effectively extinguish the fire without feeling the heat.



**Incorrect Way**

When dry chemical is shot into the center of the fire, the fire continues to burn.



**Correct Way**

Immediate extinguishment is achieved when the dry-chemical stream is swept at the base of the fire where the fuel source is located.

**Types of Fires**

**Class A Fires**

- Wood
- Paper
- Plastic
- Rags



**Class B Fires**

- Gasoline
- Oil
- Grease
- Paint



**Class C Fires**

**Electrical**

- Office Equipment
- Motors
- Switchgear
- Heaters



**Class D Fires**

**Metals**

- Potassium
- Sodium
- Aluminum
- Magnesium



The National Fire Protection Association (NFPA) has classified four types of fires.

### Types of Fire Extinguishers

**Types of Extinguishers**

Classified by the type of fire on which they may be used.



**Class A**

Used on  
Wood, Paper,  
Plastic, Cloth



**Class B**

Used on  
Flammable  
Liquid Fires



**Class C**

Used on  
Electrical  
Fires



**Class D**

Used on  
Metal Fires



## How to handle small LP gas fires with portable fire extinguishers

It is important to react quickly in the event of a fire involving liquefied petroleum (LP) gas. The following are recommendations of the National Propane Gas Association.

### *Should the fire be extinguished?*

In any LP gas fire, flames should not be extinguished unless by doing so the fuel supply can be turned off. If the fire is extinguished and a supply of fuel is not turned off, an explosion hazard much greater than the fire hazard may be created. Accordingly, firefighters should be trained not to extinguish a flammable gas fire until a definite plan of fire control has been established, fuel shut-off has taken place, and each person has been instructed about his or her part of the operations.

During this planning period, water spray from hand hose lines or fixed piping can be directed upon the equipment to prevent overheating.

### *Attack the fire from upwind.*

Fires created by ignition of LP gas escaping from leaks caused by equipment failure must be contained from an upwind position. The dry-chemical stream is directed into the gas flow, using the velocity of the gas to help draw the extinguishing chemical out of the extinguisher.

Hold your dry-chemical stream on the escaping fuel behind the point of combustion. Do not chase after the ball of fire. After the fire is extinguished, you and your extinguisher should remain close by and ready as standby protection against reflash during the time people are working to stop the flow of fuel.

### *Recharge the extinguisher immediately.*

Every fire extinguisher should be recharged immediately after use. A partially filled extinguisher, for all practical purposes, is an empty extinguisher. Do not return it to its normal location; instead, invert the extinguisher, return it to an upright position and transport it to your recharge station.

### *Inspections and Regulations*

All fire extinguishers must be visually inspected every 30 days and a permanent record maintained. At least once each year, complete maintenance in accordance with the manufacturer's instructions must be made and recorded. At five- to 12-year intervals, a hydrostatic test on each extinguisher is required.

This section only provides a brief review of the operation and applications of dry-chemical, portable hand fire extinguishers.

There are other fire extinguisher and fire safety regulations and recommendations published by other related organizations you should be aware of. These include:

- OSHA regulation: General Industry Regulation 1910.57 Portable Fire Extinguishers
- NFPA publications: Publications 241 and 51B

### FIRE SAFETY TICK-TACK-TOE

<p>Fill in the blank:</p> <p>A minimum of _____ 4A60BC fire extinguishers should be readily available within 10 feet of all torching activities.</p>	<p>What does the plastic seal band through the release pin of a fire extinguisher ensure?</p>	<p>Name one thing you <u>should do</u> and one thing you <u>should not do</u> when tending to a regular burn victim.</p>
<p>Name two things that <u>should</u> be done for victims of propane freeze burn.</p>	<p>What words does the term PASS stand for?</p>	<p>Name two materials that— if they were on fire— would be classified as Class A fires.</p>
<p>Name three types of PPE that should be used while doing torch work.</p>	<p>What classification of fire extinguisher should be within 10 feet of torch work?</p>	<p>What should be done with a fire extinguisher that has been discharged?</p>

# Section 2 PRE-JOB PLANNING AND PREPARATION

## Pre-job Inspections and Checklist

A comprehensive pre-job inspection should be performed before the start of any torching activity on a roof. Conducting a comprehensive inspection includes working with a building owner or representative on a daily basis. An owner has a working knowledge of the building's operations that may create hazards you are not aware of. Because job-site conditions can change from day to day, NRCA and MRCA recommend this inspection be conducted before the start of each workday. If the work involves rotating shifts, inspections should be conducted before the start of each work shift. The intent of performing pre-job inspections is to identify hazards associated with using torches on roofs and implement preventive measures to help minimize the potential for injury or property damage.

As a certified roofing torch applicator, you may or may not be involved with conducting pre-job inspections. However, it is important you are aware of the need for pre-job inspections and how they are conducted.

### Conducting Pre-job Inspections

An inspection does not have to be complicated or require a lot of time. In fact, proper daily inspections are effective ways to increase productivity. Inspections help avoid problems and minimize risks. When using a torch, additional risks are present and daily inspections become an effective prevention tool. In addition to CERTA safety guidelines, you also are required to comply with Occupational Safety and Health Administration regulations and local building codes.

NRCA and MRCA recommends using a checklist during daily inspections. There is a Daily Inspection Checklist in the appendix of this manual (see pages 55-58) you can use for this purpose. You will notice the checklist includes a section for specifically identifying preventive measures. Be sure you and your inspection team identify how each hazard is to be addressed and include as much detail as practical.

A daily inspection checklist should be signed and dated by everyone involved in the inspection. This includes the building owner, crew foreman or superintendent, lead man and anyone else contributing to the inspection process. This document should be kept in a safe place and returned to your company's office to be saved in the job file. No checklist can address all possible hazards, so be alert for hazards not included on a checklist and record them in detail.

## Identifying Hazards and Preventive Measures

Following are descriptions of common roofing job-site hazards associated with torch work that you should be aware of and look for before you start torching work. Also provided are control measures that may be implemented to eliminate or minimize each hazard.

### General Working Conditions

Before the start of any activities involving torches, assess the work area and ensure general conditions are favorable for working with torches.

#### *Housekeeping*

Hazard: Loose materials can blow into torch flames, creating a fire hazard.

Controls: - Remove all trash and debris from the work area.

- Maintain good housekeeping practices throughout the course of each day.

#### *Fall Protection*

Hazard: Exposed edges, openings or holes more than 6 feet above the lower level create fall hazards.

Controls: - Be sure guardrails, personal fall-arrest equipment, hole covers, warning-line systems and competent safety monitors as required for the job are in place.

- All employees should receive training in how to use fall-protection systems and equipment.

Hazard: Tripping hazards exist from torch equipment and hoses. Tripping over a hose attached to a lit torch also can create fire hazards.

Control: Position equipment and hoses during the course of work to minimize risks of tripping and falls.

### ***Ventilation***

Hazard: Liquefied petroleum (LP) gas and other vapors are heavier than air and may pool in low or poorly ventilated locations.

- Controls:
- Identify areas with poor ventilation or low areas likely to collect heavier gases and vapors.
  - Confirm pooled LP gas or vapors are not present in identified areas.
  - Use of mechanical ventilation to force air movement in these areas may be required.

### ***Job-site Conditions***

Hazard: Building use or job-site conditions may change from day to day.

- Controls:
- Review daily with the building owner for possibilities of any changed conditions that could present hazards during torching activities.
  - Make sure changed conditions have been compensated for or corrected in the agreement with the building owner.

### ***Weather Conditions***

Hazard: Wind conditions may cause torch flames to extend farther than normal.

- Controls:
- Remind all roofing workers that windy conditions can extend flame spread.
  - Increase distance of torch head from hazards so the flame is not spreading unseen into hazardous areas.
  - Cease torching operations if the flame spread cannot be controlled.

Hazard: Bright sunlight limits open-flame visibility.

- Controls:
- Remind all roofing workers that bright sunlight may limit their ability to see open flames.
  - Increase the distance of open flames to hazardous areas when the flame cannot readily be seen.

## **Fire Safety**

Before starting any torching activities, make sure all fire-safety precautions for working with torches are implemented.

### ***General Fire Safety***

Hazard: Uncommon hazardous conditions may be present that are not easily identifiable.

- Controls:
- Local building codes or regulations may identify specific local or regional hazards not commonly recognized.
  - Check and comply with all local building codes and regulations.

Hazard: Workers want to smoke in or around the work area.

- Controls:
- No-smoking areas should be clearly communicated to anyone with access to the work area, including roofing workers, building owners and the general public.
  - Posting no-smoking signs is recommended if access to the work area is not in full control of the roofing contractor.

Hazard: Combustible or flammable materials, such as materials stored in shrink-wrap or covered with tarps, are stored within 20 feet of anticipated torching operations.

- Control:
- Relocate or remove combustible or flammable materials a minimum distance of 20 feet from anticipated torching operations.

### ***Fire Extinguishers***

Hazard: Fire extinguishers may not be effective for some fires.

- Controls:
- All fire extinguishers should be fully charged, 4A60BC.
  - Each torch operator should have a fire extinguisher within 10 feet of the torching work.
  - A minimum of two fire extinguishers should be readily available within 10 feet of all torching activities.
  - Fire extinguishers should not be placed closer than 10 feet to any propane cylinder.
  - All fire extinguishers should have a valid up-to-date inspection tag affixed, provided by an authorized service provider.

- All fire extinguishers should have a plastic seal band in place through the release pin.
- Discharged or partially discharged extinguishers should be removed from the job site.
- All personnel involved with torching activity on a roof should be trained in proper fire-extinguisher use (see PASS system in Section 1, page 12).

### ***Emergency Communications***

**Hazard:** It may be difficult to contact the local fire department or emergency services in the event of a fire.

- Controls:**
- The local fire department telephone number and the job-site address should be clearly posted at the roof access point.
  - The closest telephone access should be identified and communicated to all crew members.
  - A working cell phone with a fully charged battery should be available on the roof; the local fire department telephone number should be preprogrammed into the telephone for the duration of the job.

### **Specific Job-site Hazards**

Before the start of any torching activity, ensure specific job-site hazards are identified and control measures are taken. Many of these specific job-site hazards are addressed in more detail, including procedures for hazard controls, in Section 4, Application Safety, of this manual.

**Hazard:** A plywood, oriented strand board (OSB) or wood plank roof deck or other type of deck that you cannot identify as noncombustible are present.

- Controls:**
- If above-deck thermal insulation is NOT present over the roof deck, incorporate a thermal barrier into the roof system. Note: A base ply alone does not qualify as a thermal barrier.
  - Establish regularly scheduled under-deck inspections during all torching activities as agreed upon in advance with the building owner.

**Hazard:** Combustible or flammable materials may be present immediately below the roof deck.

- Controls:**
- Inspect below the roof deck for adjacent combustible or flammable materials, and remove them until torching activity is completed.

**Hazard:** Plywood, OSB, wood plank, wood fiberboard or other type of materials that you cannot identify as noncombustible are present as the flashing substrate.

- Controls:**
- If combustible flashing substrates are present, including cant strips, incorporate an approved backer layer into the flashing detail design and installation. (See CERTA Safety Practices for Roofing Torch Use on page 2.)
  - Do one of the following:
    - Implement the torch-and-flop installation method
    - Implement the cold-applied adhesives method
    - Implement the mop-applied with hot bitumen method
    - Implement the direct torching method using a small detail torch (105k Btu or less)

**Hazard:** Combustible adjacent building components are present, including but not limited to:

- Window sills
- Door thresholds
- Siding materials

- Controls:**
- Identify combustible adjacent building components.
  - Remove combustible adjacent building components whenever possible.
  - Implement a torch-and-flop, cold-applied or mop-applied installation method when installing materials near adjacent building components that are combustible.
  - Implement a thermal barrier when installing materials near adjacent building components that are combustible.
  - No direct open flame should contact these adjacent building components.

**Hazard:** Concealed attic or crawl space is present immediately below a plywood, OSB, wood plank or roof deck or other type of deck that you cannot identify as noncombustible.

- Controls: - Consult with the building owner to identify and gain access to concealed attic and crawl space areas to fulfill regular daily inspections.
- Visually inspect attic and crawl space areas for concealed hazards.
- Hazard: HVAC service lines or utility pipes are present.
- Controls: - Identify contents of all utility lines and pipes penetrating or lying on a roof before the start of any torching activities (e.g., electrical wiring, natural gas service pipes for rooftop HVAC units).
- Temporarily disconnect and remove utility lines and pipes before the start of torching activities whenever possible.
  - Communicate to all roofing workers the location and types of utility lines and pipes present.
  - Implement torch-and-flop, cold-applied or mop-applied methods when installing materials around service lines and utility pipes.
  - No direct open flame should contact any utility line or pipe.
- Hazard: Rooftop penetrations are present, including but not limited to:
- Static vents
  - Powered exhaust or intake vents
  - Plumbing and sewer vents
  - Skylights
  - Vent support curb flashings, including cant strips
  - Interior roof drains
- Controls: - Remove any abandoned rooftop penetrations, and repair the deck opening.
- Consult with the building owner to shut down all operating intake and exhaust vents.
  - Implement torch-and-flop, cold-applied or mop-applied methods when installing any roofing material around rooftop penetrations.
  - No direct open flame should contact any rooftop penetration or openings.
- Hazard: Flammable or explosive vapors or gases are being exhausted near the roof.
- Controls: - Consult with the building owner to help identify contents of any vapors or gases exhausted through vents or equipment.
- Shut off the source of flammable or explosive vapors or gases.
  - Methane and other flammable gases are common components of sewer gas. Check with local building or public service departments for possible presence of these gases in a sewer system.
  - Implement torch-and-flop, cold-applied or mop-applied methods when installing materials around sources.
  - No direct open flame should contact any exhaust or vent opening.
- Hazard: Rooftop mechanical equipment is present, such as:
- HVAC units
  - Condensing units
  - Water chillers
  - Air-filtering units
  - Through-wall air intake or exhaust vents or louvers
  - Grease traps
  - Collection devices for lint or sawdust
- Controls: - Inspect equipment from below deck for combustible or flammable materials.
- Consult with the building owner to ensure all flammable or combustible materials are cleaned and removed from filtering and collection devices. Note: The CERTA program does not recommend roofing contractors perform this type of maintenance on building owners' equipment.
  - Consult with the building owner to shut down any through-wall air intake and exhaust vents and louvers.

- Identify with the building owner other sources of air intake to avoid negative-pressure buildup inside the building.
- Implement the torch-and-flop, cold-applied or mop-applied method for installing materials around or near roof-mounted equipment.
- No direct open flame should contact any rooftop mechanical equipment or their openings.

Hazard: Additional wall or flashing components are present, including but not limited to:

- Counterflashings
- Coping caps
- Through-wall scuppers
- Other wall penetrations

Controls: - Identify all wall and flashing components.

- Remove wall or flashing components until torching activity is completed whenever possible.
- Implement torch-and-flop, cold-applied or mop-applied method when installing any roofing material near wall or flashing components that are left in place.
- No direct open flame should contact any wall or flashing component.

NOTE: If you are certain all edges and flashings are sealed and pose no fire threat, direct torching (using a small detail torch, 105k Btu or smaller) method may be used.

Hazard: Perimeter edges are present, including but not limited to:

- Gravel stop flashings
- Gutter edge flashings
- Exposed roof edges
- All other embedded edge flashing details

Controls: - Implement torch-and-flop, cold-applied or mop-applied methods for starting rolls along edges.

- Implement torch-and-flop, cold-applied or mop-applied methods for installing stripping plies on embedded edge flashings.

Note: If you are certain all edges and flashings are sealed and pose no fire threat, then direct torching (using a small detail torch, 105k Btu or smaller) method may be used.

## In-progress Job Inspections

During the course of daily torching activities, ensure changing job-site conditions are identified and control measures are taken.

### *Unattended Torches*

Hazard: Unattended operable torches, lit or unlit, may cause fire or explosion.

Controls: - If torching activities are stopped for any period of time and torches are left unattended (including lunch or rest breaks), shut off supply valves, clear gas lines and shut off all torches before leaving the work area.

- At no time should a lit torch be left unattended.

### *Under-deck Inspections*

Hazard: Plywood, OSB, wood plank, any type of deck that you cannot identify as noncombustible or adjacent materials on the underside of decks may smolder, build up heat and eventually burst into flames if unnoticed during the course of torching activities.

Control: - A competent person should conduct scheduled under-deck inspections at regular intervals during the course of torching activities when combustible roof decks or flashing substrates are present. The frequency of inspections should be determined by the type of torching activities; the type of thermal barrier being used; the openness and accessibility of the deck's underside; and the agreed-upon schedule made during pre-job planning with the building owner.

## Post-job Inspections

At the end of each workday and on completion of the job, equipment and cylinders must be secured or removed and a fire watch maintained for sufficient duration.

**Securing the Job Site**

Hazard: LP gas cylinders remaining on a roof after daily use may be blown over by wind gusts, accidentally be knocked over, or roll off exposed roof edges and rupture and explode.

- Controls: - Secure all LP gas cylinders in accordance with National Fire Protection Association standards at the end of each workday.  
 - Safety-check all equipment and LP gas cylinders at the completion of each workday.

**Fire Watch**

Hazard: Plywood, OSB, wood plank, any type of deck that you cannot identify as noncombustible, flashing substrates and adjacent materials on the underside of decks may smolder, build up heat and eventually burst into flames if unnoticed during the course of torching activities.

Control: - A competent person should conduct a comprehensive fire watch for a minimum of two hours after torching activities end. Details regarding a comprehensive fire watch can be found in Section 5, Post-job Requirements and Duties, of this manual.

**JOB-SITE HAZARDS AND CONTROLS MATCHING**

<b>HAZARDS</b>	<b>CONTROLS</b>
<p><i>General Working Conditions</i></p> <p>_____ Loose materials can blow into torch flames.</p>	A. Closest telephone access should be identified and communicated to all crew members.
<p><i>Weather Conditions</i></p> <p>_____ Wind conditions may cause open flames from torching equipment to extend beyond normal visibility.</p>	B. If above-deck thermal insulation is NOT present over the roof deck, incorporate a thermal barrier into the roof system. Note: A base ply alone does not qualify as a thermal barrier. (See CERTA Safety Practices for Roofing Torch Use on page 2.)
<p><i>Weather Conditions</i></p> <p>_____ Bright sunlight limits open-flame visibility.</p>	C. Remove all trash and debris from the workplace.
<p><i>Specific Job-site Hazards</i></p> <p>_____ Plywood, OSB, wood plank, wood fiberboard or unidentifiable flashing substrates are present.</p>	D. Increase the distance of open flames to hazardous areas when flames cannot readily be seen.
<p><i>Specific Job-site Hazards</i></p> <p>_____ Rooftop penetrations are present.</p>	E. Consult the building owner to identify and gain access to concealed attics and crawl spaces to fulfill regular daily inspections.
<p><i>Specific Job-site Hazards</i></p> <p>_____ A plywood, OSB, wood plank or unidentifiable roof deck is present.</p>	F. Cease torching operations if spread cannot be controlled.
<p><i>Specific Job-site Hazards</i></p> <p>_____ Concealed attics or crawl spaces are present immediately below a plywood, OSB, wood plank or unidentifiable roof deck.</p>	G. If combustible flashing substrates are present, including cant strips, a two-layer backer should be incorporated into the flashing detail design and installation.
<p><i>Emergency Communications</i></p> <p>_____ It may be difficult to contact the local fire or emergency services department in the event of a fire.</p>	H. Direct open flames should not contact any rooftop penetration.

## Section 3

# PROPANE TOOL AND EQUIPMENT SAFETY

The propane-fueled tools and equipment used in roofing work can be helpful with roof system installation efficiency. Too often, though, these tools and equipment are improperly used or used for the wrong purpose. Serious fires, explosions, injuries and deaths have occurred because of careless or improper use of this potentially dangerous equipment. A propane tank is a fuel source and can explode. This section will examine each component of torch assemblies and proper ways of addressing their hazards.

## Propane Gas Characteristics

Propane belongs to a family of gases known as liquefied petroleum LP gas. Propane is a vapor at room temperature and atmospheric pressure. It liquefies under moderate pressure and vaporizes when the pressure is released. This property of propane permits it to be transported and stored in concentrated liquid form and used as a fuel in vapor form.

Propane vapors are heavier than air. It only takes an extremely small amount of this gas combined with air to make a highly explosive mixture.

Propane does not have a detectable odor, but manufacturers add ethyl mercaptan to propane to give it a distinctive rotten egg odor so it can be detected.

When LP gas vaporizes, it expands from its liquid state at a ratio of 272:1. This means the gas will expand to more than 270 times its liquid volume when the pressure is released.

It is important to understand how propane works for you to work safely. The key precaution is that the flow and burn of propane must be controlled for you to be safe.

## Torch Assemblies

The tools and equipment you use to control the flow and burn of propane gas make up a torch assembly. You will need to understand each component of a torch assembly (see Figure 1) to use one safely. We will look closely at each torch assembly component, which includes:

- Torching apparatus (hand torch or torching trolley)
- Propane gas cylinder or tank
- Pressure regulator
- Hose and hose connections

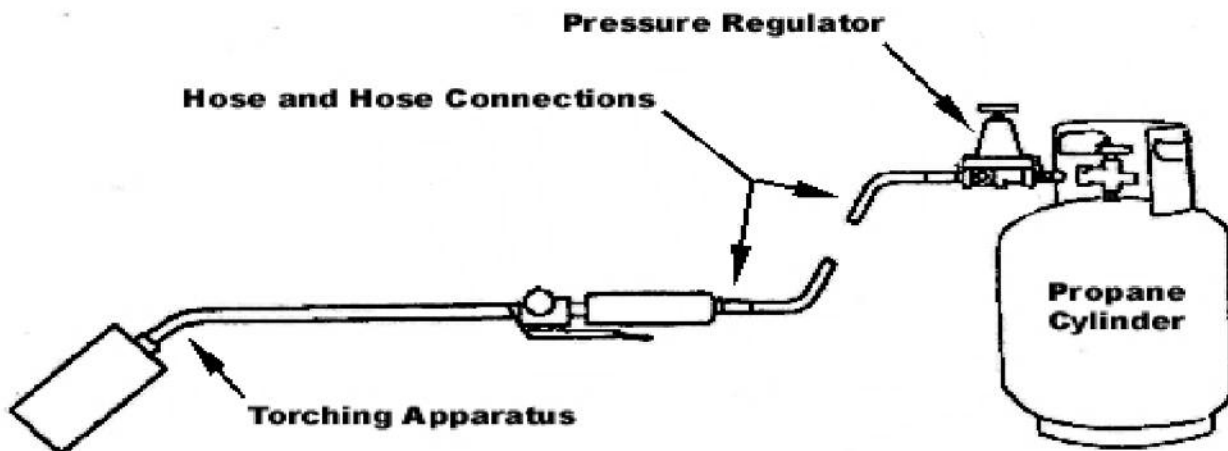

Figure 1: A complete roofing torch assembly

## Torching Apparatuses

### Hand Torches

There are a variety of hand torches available, and each is designed to perform certain tasks, such as installing large or small flashing details, field plies or seam details. Torches differ by size and number of torch burner heads and heat output. Heat output is measured in units called British thermal units (Btu). One Btu is approximately equivalent to the heat energy produced by burning one wooden kitchen match. Many torches produce flame temperatures in excess of 2,000 F.

The torch unit should be manufactured so it does not leak under normal and continual use. It should be listed by Underwriters Laboratory (UL) Inc. Figure 2 shows the basic components of every torch. A torch should have a pilot-control valve, high-pressure valve trigger lever and an on/off control valve at the inlet connection.

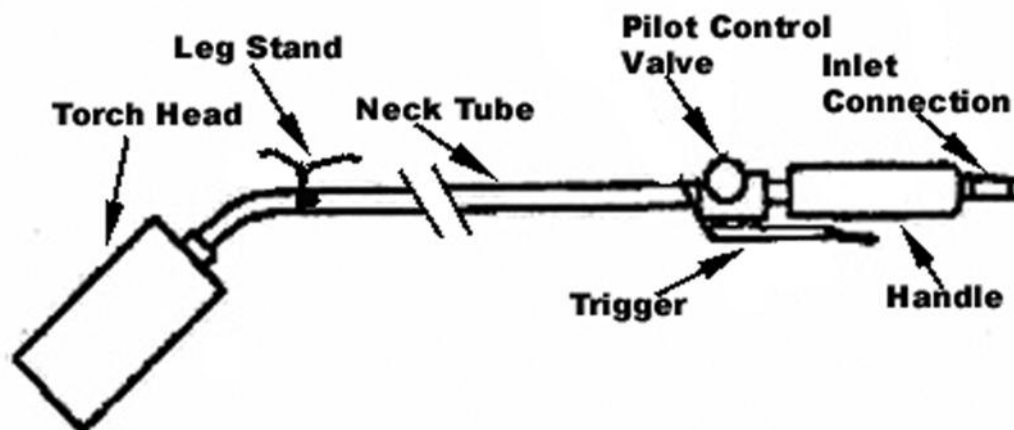

Figure 2: Basic components of a roofing torch

The neck tube should be a comfortable length for the work being done. All hand-held torches should have a leg stand designed so you can set the torch down momentarily and direct the flame away from the roof surface. The torch head is attached to the end of the neck tube. The torch head mixes propane fuel with air to produce a flame.

### Torch Sizes

Generally, larger torch heads produce a larger quantity of heat with a longer flame spread, and smaller torch heads generally produce less heat and a shorter flame spread. For example, a detail torch typically will have a relatively small head, produce approximately 50,000-105,000 Btu and project a relatively short flame. A shorter neck tube also is typically included with a detail torch. A shorter flame spread can be more easily controlled and help reduce the fire hazard.

Hot-air welders are used sometimes for installing torch-applied roof systems. Temperatures generated by hot-air welders can be as hot as an open-flame torch; therefore, use the same precautions and care when using hot-air welders to avoid fire and personal injury.

Table 3.1 below lists the basic types and output of hand torches commonly used to install torch-applied polymer-modified bitumen sheet products.

Hand Torch Sizes	
Type	Output, Btu
Detail torch	50,000 to 105,000 Btu
Mid-size torch	105,000 to 350,000 Btu
Large field torch	350,000 to 600,000 Btu

Table 1: Hand torch sizes

**Torching Trolleys**

Installation of field plies also can be done using torching trolleys (see Photo 1). All torching trolleys should be manufactured with the same basic components as a hand torch. Individual burner control valves and adjustable torch head designs can help achieve more even flame spread on membrane rolls under various weather conditions. It is important you use only the torching trolley manufacturer’s recommended pressure regulator. Torching trolleys typically operate using higher gas pressures than hand torches, and using a mismatched regulator could result in a fire or an explosion. Propane cylinders must also be matched to the higher fuel demands of torching trolleys.

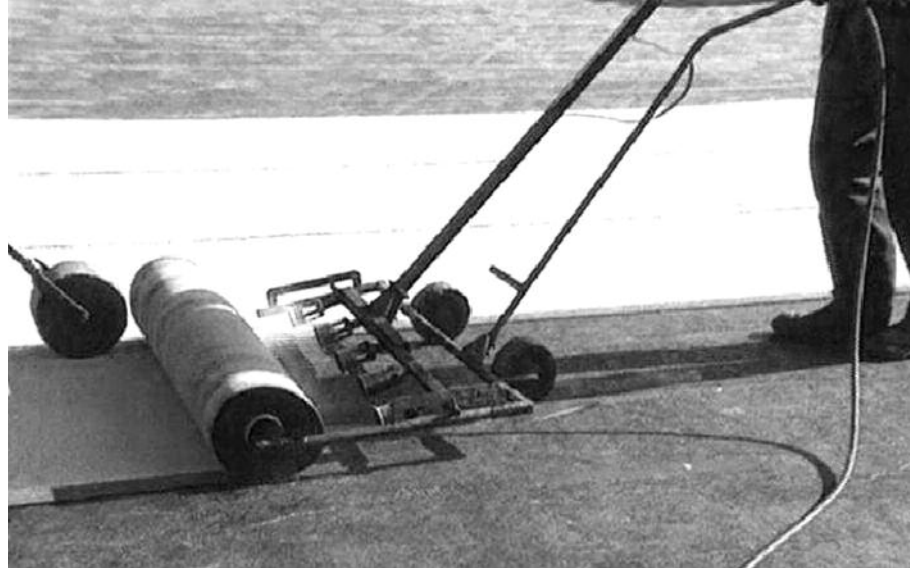

Photo 1: Torching trolley

**Propane Cylinders and Valves**

Propane cylinders are manufactured with several built-in safety features. Photo 2 shows the major components of a propane cylinder, which include a protective collar, cylinder valve and foot ring.

Propane cylinders have a manufacturing date stamped onto the tank body. If a cylinder is 12 years old or more, it must be periodically “requalified” to ensure it is safe for continued service.

**Protective Collar**

The protective collar is a guard protecting the cylinder valve from accidental damage. If a tank falls over and the valve assembly breaks off, the fast escape of propane gas would act as a propellant, turning the tank into a dangerous projectile.

The large quantity of propane fuel escaping also would create an immediate fire and explosion hazard. Protective collars are an important component in propane equipment safety.

They are designed to withstand a blow from any direction equivalent to that of a 30-pound weight dropped 4 feet. If a protective collar is damaged or missing, the propane tank should immediately be removed from service.

**Cylinder Valves**

Cylinder valves are the key components of propane cylinder use and safety. You need to understand how cylinder valves work and how to maintain and properly use them.

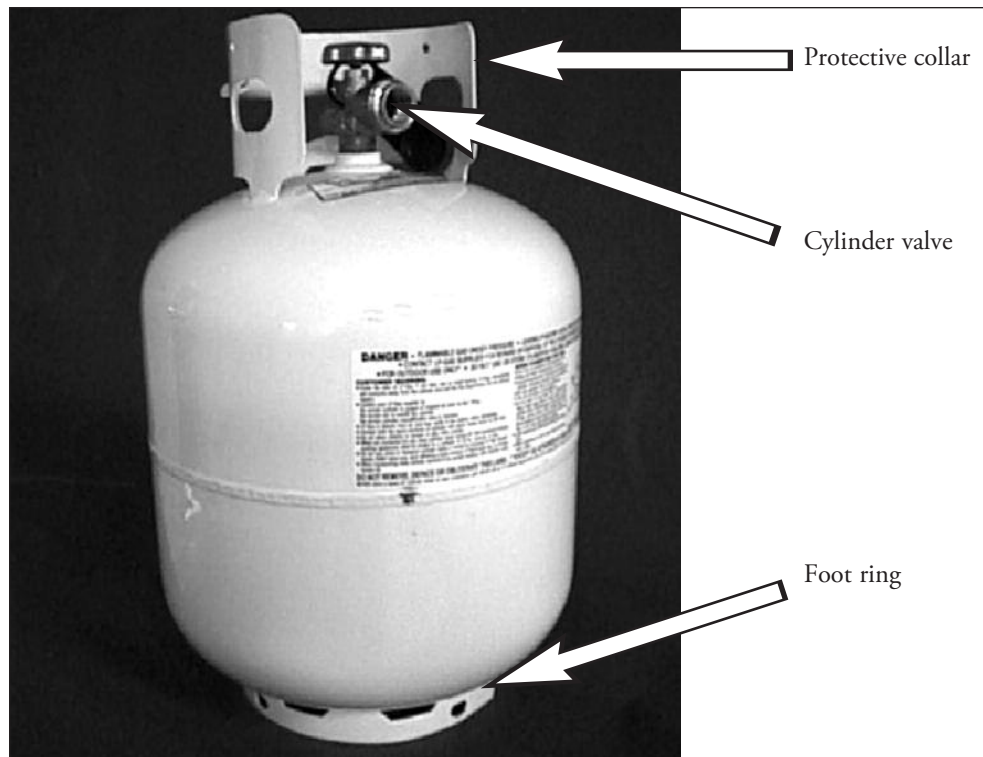

Photo 2: Propane cylinder components

Photo 3 shows the parts of a standard Overfill Protection Device (OPD) cylinder valve. Federal law requires all propane cylinders be fitted with an OPD-type valve.

The OPD device has an attached float to prevent overfilling the cylinder (see Figure 3). Cylinders must never be filled above 80 percent of capacity because gas expands with increases in temperature. The OPD should never be relied upon to indicate a tank is almost full. If an older cylinder is requalified, NFPA 58 requires the cylinder to have a new OPD valve installed. NFPA 58 also requires all small propane cylinders have an OPD installed. Cylinders should only be filled by a qualified professional.

**Safety Tips for Cylinder Valves**

Always operate a cylinder valve using the hand wheel. Open the valve slowly and fully. Never use a tool to forcibly turn a valve hand wheel. Forcing the valve hand wheel too far may loosen the valve bonnet, resulting in uncontrolled discharge of gas. If a hand wheel is stuck, remove the cylinder from service and have it inspected.

If you notice damage to any part of a cylinder valve or a valve leak is detected, do not attempt to repair the valve; it must be replaced.

The pressure-relief valve is a spring-loaded safety device that opens only when there is excessive cylinder pressure. Pressure-relief valves are sealed at the factory; you should not try to repair them. Leaking pressure-relief valves must be replaced by an authorized repair person.

It is your responsibility to keep the outlet of the pressure-relief valve clean so it will function properly. Visually inspect it each time the cylinder is filled to be sure the valve is free of foreign material.

Do not inspect, stand over or stand in front of pressure-relief valves when a tank is being filled. The valve could discharge without warning if there is excessive pressure.

**Foot Ring**

Propane cylinders always should remain upright. The foot ring provides stability for standing tanks. If a foot ring becomes loose, damaged or broken, remove the tank from service. Do not risk the hazards of a tank falling over and possibly damaging the tank or breaking its valve.

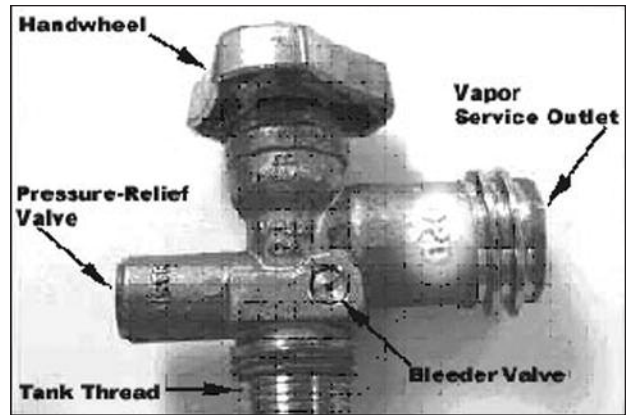

Photo 3: OPD cylinder valve

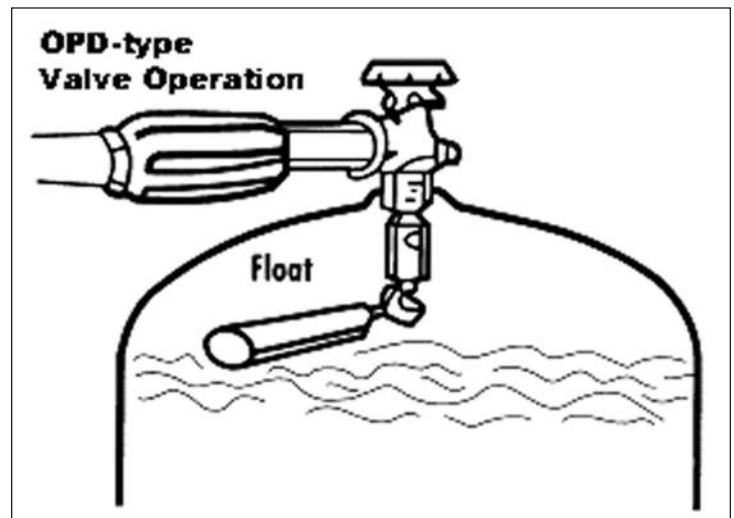

Figure 3: OPD valve operation

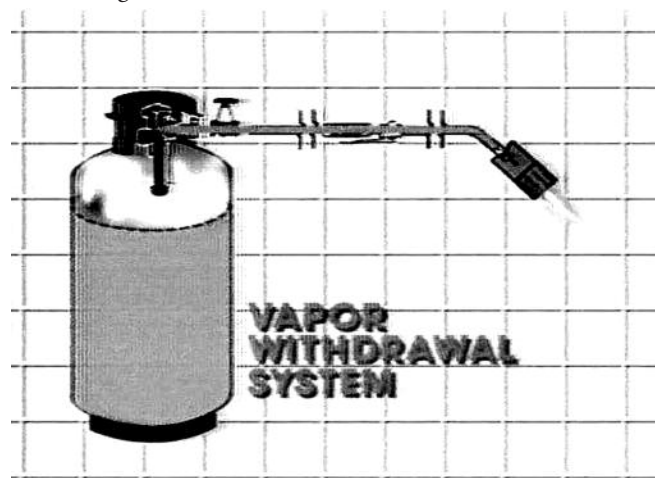

Figure 4: Vapor collects at the top of a tank.

**Propane Cylinders**

**Propane Cylinders as Containers**

Two types of propane tanks are used for roofing work: vapor withdrawal and liquid withdrawal.

In vapor-withdrawal systems, vapor collects in the space above the liquid in the tank (see Figure 4). The vapor is drawn off and burned at the torch head. Note the liquid propane level inside the tank is approximately 80 percent of the volume and should never be filled to more than this level. Vapor-withdrawal tanks have a female valve fitting for hose connection. Most roofing torch equipment is designed to work on a vapor-withdrawal system.

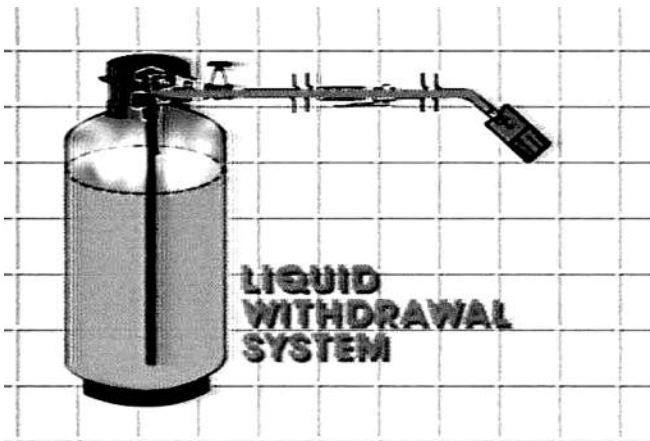

Figure 5: Liquid fuel is drawn from the bottom of the tank.

Liquid-withdrawal systems have a dip tube attached to the cylinder valve that draws liquid propane from near the bottom of the tank (see Figure 5). The liquid is carried to the torch head, where the liquid is vaporized and burned. All liquid-withdrawal cylinders manufactured since 1988 have a male threaded (CGA 555) valve. It should be noted that some 100-pound liquid-withdrawal cylinders manufactured before 1988 were available with a POL-style, or female threaded (CGA 510), valve.

Check for the manufacturing date stamped on the top of all propane cylinders. If a cylinder is older than 1988 and has a POL-style female threaded outlet, do not use it with a torch assembly designed for vapor-withdrawal systems or an explosion or fire could occur.

The type of torch used with a liquid-withdrawal system differs from a torch used with a vapor system. In a liquid system, the liquid propane is carried through the hose to the torch head and passes through a heating device that vaporized the gas before it is burned. These torches typically are heavier than vapor torches. Liquid-withdrawal systems have an advantage in colder climates because they will not frost.

Although some torches designed for liquid-withdrawal systems may be used with vapor-withdrawal systems, **you cannot use vapor-withdrawal torches with a liquid system. Doing so will create a continuous uncontrolled fireball of burning liquid propane.**

**Never** turn a vapor-withdrawal cylinder on its side or upside down to try to use a liquid torch or to try to get more propane out of a low tank. Raw liquid propane could expel, and the safety relief valve may open. The pressure on the liquid propane will not be relieved, and an enormous amount of liquid will escape and create a potentially explosive fire hazard.

**Handling, Hoisting and Storing Propane Gas Cylinders**

An important aspect of working with torching equipment is the safe lifting, moving and storing of cylinders at job sites. Refer to NFPA 58 for proper handling of LP gas containers.



Photo 4: Tank dolly

**Handling tanks**—When moving cylinders, securely fasten them in an upright position on a dolly or cart device designed for that purpose (see Photo 4). Moving a 5-, 10-, 20- or 40-pound cylinder by hand without a cart should be done by gripping the protective collar, not the valve. Two people should move a 100-pound cylinder; do not attempt to lift one alone. One person should firmly grip the foot ring while the other grips the protective collar (see Photo 5). You should never lay tanks on their sides and roll them to get them from one place to another. This practice creates serious hazards.



Photo 5: This is the proper way to carry a 100-pound cylinder.

**WARNING!** Breaking off a valve will create an immediate hazardous condition. If a valve does break off, the tank literally may launch like a rocket if unsecured.

**Hoisting tanks**—Close the cylinder valve, and plug or cap the valve outlet. Put a protective collar or cap in place while raising or lowering cylinders. However, a collar or cap may not provide sufficient valve protection in the event a cylinder is dropped from a truck bed, scaffold, loading dock or roof or while hoisting it to another level.

If you are hoisting cylinders more than *30 inches*, securely fasten them in an upright position in either a protective hoisting cage or properly balanced box of enclosing mesh. The cage or box must be constructed to provide the protection necessary to the cylinder and its valve in case of a hoisting failure or accident. This hoisting requirement is mandated by the Occupational Safety and Health Administration.

A rope sling through protective collars must not be used to hoist cylinders. You may not use the cylinder valve in any manner to assist in raising or lowering a cylinder. Avoid dropping or bumping cylinders as they are raised or lowered.

**Storing tanks**—Take the following steps to ensure safe overnight job-site storage of all propane cylinders:

- Treat empty and full tanks the same.
- Group all cylinders together, and secure them upright for overnight storage. You can use a “come along” binding strap secured around the middle of the tanks.
- Close cylinder valves, and make sure protective caps and collars are in place. No tank should be left without valve protection.
- Store containers at least 10 feet from any building or adjoining property, sidewalk, busy thoroughfare or public gathering place.
- When LP gas systems are in close proximity to vehicular traffic, use traffic barriers or other precautions.
- Disconnect all regulators and hoses, and install plastic valve plugs.
- Do not store any other materials around or on top of the cylinders.
- Check local codes relating to cylinder storage on rooftops. Contact the local fire department for propane cylinder storage codes.
- Select the best location on the rooftop to store tanks. Try to locate them at least 10 feet from any edge; away from walls, drains, vents, etc.; and where they won’t block passages.
- Place fire extinguishers in visible locations for all storage areas.
- Store cylinders in shaded areas whenever possible.
- Refer to NFPA 241 for other recommendations for propane tank storage.

**Cylinder transport**—Be familiar with all federal, state and local department of transportation regulations pertaining to the transportation of propane cylinders. Your vehicle may require a placard identifying the gas you are transporting.

## Pressure Regulators

Pressure regulators are the heart of a roofing torch assembly. Pressure regulators reduce high cylinder pressures to safe working pressures, making them one of the most valuable safety devices for controlling the burn and flow of highly flammable and explosive propane gas. An improperly used or malfunctioning regulator may cause operational problems, property damage, injury or death.

Only *adjustable* pressure regulators supplied by the torch apparatus manufacturer should be used. A typical adjustable pressure regulator has a pressure adjustment knob, pressure gauge and vent hole in addition to a gas inlet and outlet (see Photo 6). The inlet and outlet often are marked on the regulator. It is important the regulator vent be kept clean and remain open so air can pass in and out as the regulator diaphragm moves. Vents can become plugged with mud, bugs, bitumen and other foreign matter.

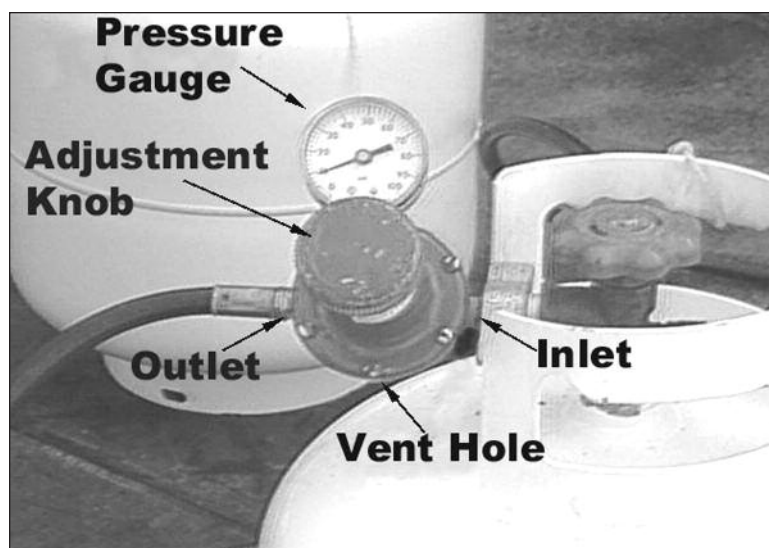

Photo 6: Adjustable pressure regulator assembly

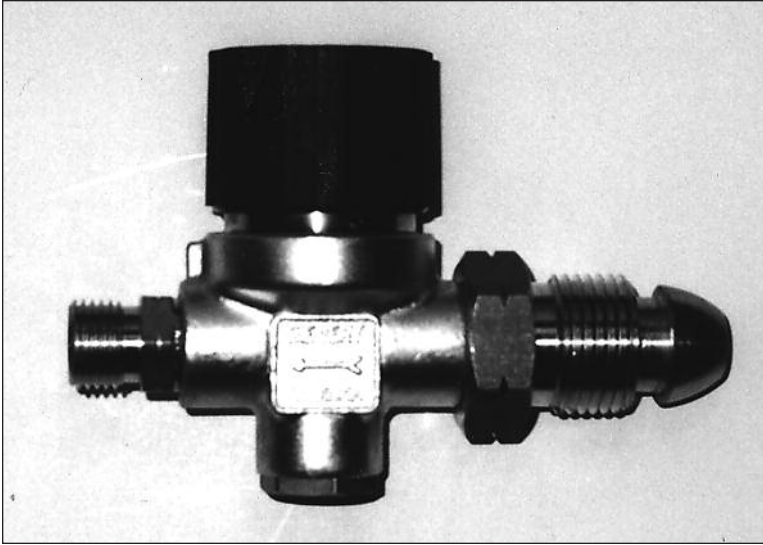

Photo 7: Preset-type pressure regulator is shown.

Regulators are designed to work either on liquid- or vapor-withdrawal cylinders. All regulators should be listed by Underwriters Laboratories (UL) Inc. A new regulator may require some assembly. Be sure to read and follow any instructions supplied by the manufacturer. Be sure only to use connectors approved by the Compressed Gas Association if connections are required and not provided by the manufacturer.

Pressure gauges are recommended to monitor gas flowing through a regulator. Some regulators are manufactured without gauges. Instead, they use a preset marking system to indicate the pressure setting. These regulators are only for use with specific torches. Photo 7 shows a typical preset regulator without a pressure gauge. Again, only use a regulator recommended by the torch manufacturer.

Be sure to match a regulator with the torch equipment you are using. Multihead torches and torching trolleys operate using higher pounds per square inch (psi) settings than single-head torches. Do not mismatch regulators and torches, or you may create additional fire and explosion hazards. Again, always refer to manufacturers' specifications for matching regulators with torches.

Normal working pressure for most torching apparatus is between 30 to 60 psi. Check manufacturers' requirements for optimum torch-operating pressures. A regulator should be serviced only by qualified personnel equipped with the tools needed to properly assemble and test the equipment. Be sure to only operate a torch at the pressure setting recommended by its manufacturer. Common mistakes in regulator use, such as increasing pressure to overcome windy conditions or cold weather issues, can increase the risk of fire or explosion.

## Hose and Hose Connections

Hose, hose connections and flexible connectors must resist the high-pressure action of LP gas, both liquid and vapor, and hose fittings must be UL-listed.

Hose, hose connections and flexible connectors used for conveying liquid or vapor propane at pressures in excess of 5 pounds per square inch gauge (psig) should comply with the following:

- The hose shall be designed for a minimum bursting pressure of 1,750 psig and a working pressure of 350 psig. A new hose shall be marked with "LP gas" or "LPG." The working pressure in psig shall be labeled on the hose at not greater than 10-foot intervals.
- Quick connects may also be used to mate a hose with torching apparatus. Quick connects must be listed for use with LP gas by UL.
- The shortest practical hose length should be used. As a general guideline, hose section length should not exceed 33 feet, and no more than two sections should be coupled. Additional couplers and splices should be avoided.
- LP gas-listed hoses may be used with either vapor or liquid systems.
- Hoses are rubber- or plastic-coated or a combination of both. If wire braid sheathing is used as reinforcement, it should be of corrosion-resistant material, such as stainless steel.
- A damaged hose should be pulled out of service immediately and replaced. It is recommended that all crews have replacement hoses. A hose is considered damaged if the outside covering is cut or broken in any way. Heat will damage a plastic-coated hose quickly. A damaged hose should not be repaired in the field.

**Section****4****APPLICATION SAFETY**

Installing polymer-modified bitumen membranes can be hazardous work. You know this is true, and you have heard it before. But how do you assess the things that will make your work hazardous? Identifying hazards before they cause injury or fire will go a long way toward keeping you and others safe. This section addresses equipment operation, application techniques and hazard recognition—three keys to safe torch application.

**Membrane Application**

There are three primary application methods used for polymer-modified bitumen sheet products:

- Mop-applied with hot bitumen
- Cold-adhesive applied
- Torch-applied

A membrane manufacturer's application instructions should be followed for the specific membrane you are installing. If you use the cold-applied adhesives method and you also are using a roofing torch, it is important to never allow an open flame to contact cold adhesives. Cold adhesives can be combustible and may present other fire hazards. Application instructions for the mop-applied with hot bitumen and cold-applied adhesive methods are not covered in this program.

If you are unable to identify any material in the substrate of a roof's field or flashing, you should always assume it is combustible. In these situations, do not use the direct torching method. You will need to implement other application methods listed on page 2 to reduce or eliminate the risk of fire.

**Torch Equipment Operation**

Operating torch equipment safely requires thoroughly understanding the equipment and its intended use. There are several torch-equipment manufacturers, and each manufacturer's equipment operates uniquely. This program will examine several operating features and procedures common to torch equipment from various manufacturers.

**Equipment Setup*****Connecting Fittings***

Most torch equipment typically requires some assembly. It is important to read and follow a manufacturer's instructions for assembling and operating its equipment.

When assembling torch equipment, connect all fittings by hand-tightening them first. Fittings should turn easily by hand. If they do not, the threads may be damaged. If this happens, disconnect the fittings and inspect the threads of both components for damage. Do not force a connection. Finish tightening the fittings by using an open-end or adjustable wrench. Do not use slip-lock pliers because they can damage brass fittings. Note: Some Compressed Gas Association-approved POL connections may only require hand-tightening.

Propane torch assembly fittings are designed *not* to leak when properly tightened. Thread sealant of any type should not be used unless specifically noted in the component manufacturer's assembly instructions.

***Instructions for Assembling Roofing Torch Assemblies***

1. Inspect all equipment for damage before use. Do not use damaged torch assembly components. Damaged components should be removed from service and repaired by qualified personnel.
2. Inspect the cylinder valve for dirt or foreign substances. Clean the inside of the valve with a clean rag or soft brush if necessary. Use compressed air to blow out any foreign material that may have accumulated in the valve during storage.
3. Tightly close the cylinder valve handle and regulator adjusting valve using its knob or screw.
4. Attach the regulator to the cylinder valve. Tighten the connection.
5. Attach the hose end connection to the regulator. Tighten the hose fitting snugly to the regulator outlet.

6. Open the propane cylinder valve fully while the regulator adjusting valve is still closed. Slowly open the regulator adjusting valve just enough to blow out any manufacturer's talc, spider webs or foreign matter from the hose. Close both valves.
7. Assemble a roofing torch following its manufacturer's instructions. Attach the other hose end to the roofing torch.
8. Perform a leak test. Close the torch valves, and open the cylinder valve. Open the regulator adjusting knob or screw. Apply a leak-detecting solution of soapy water to each connection, fitting and valve, as well as to the regulator body. If you see bubbles around a connection, there is a leak. First, try to re-tighten the leaking connection, but do not force it. If a connection continues to leak, close down the system, replace the leaking components and repeat the leak test. Perform a new leak test whenever you replace a cylinder or change a hose connection. **Never** apply an open flame to test for leaks.

## Lighting a Hand-held Torch

After completing the above steps, the torch assembly is ready to use. Before lighting the torch, check its owners manual for the correct operating pressure. Then, light the torch using the following sequence:

1. Wear required personal protective equipment (PPE). Review Section 1, General Requirements, of this manual if you are not sure of what PPE to wear.
2. Prepare the work area, including the following:
  - Clear the area of unnecessary equipment and debris.
  - Place two 4A60BC fire extinguishers within 10 feet of the work area.
  - Position propane cylinders a minimum of 10 feet away, and minimize cylinder movement.
  - Keep other workers back at least 3 feet.
  - Untangle hoses to avoid kinks.
3. Close all torch and propane cylinder valves. Open the regulator valve until the adjustment feels loose.
4. Holding the torch handle, direct the torch head away from your body and other torch assembly components.
5. Open the cylinder valve slowly and fully.
6. Gradually tighten the regulator knob or screw to open the regulator and adjust to the proper pressure setting.
7. Position a spark lighter near the mouth of the torch head so you can strike it as you open the pilot valve. Never use matches or a cigarette lighter to light a torch.
8. If the torch is equipped with a supply shut-off valve, open it. Then, slowly open the torch pilot valve, allowing only a small amount of gas to escape. Windy conditions will require a higher initial pilot valve setting.
9. Do not depend on hearing the sound of the propane gas before striking the lighter. Keeping the torch pointed away from your body, ignite the gas using a spark lighter.
10. Adjust the pilot flame to wind conditions so it steadily burns.
11. Test the torch's operation by opening and closing the torch trigger.

### *Auto-ignition Torches*

Some torches have an auto-ignition device called a piezo igniter that automatically lights the gas when the torch trigger is squeezed and extinguishes the torch when the trigger is released. Hold the torch away from your body, and squeeze the torch trigger. If the torch does not ignite, do not look into the burner head. Remove the torch from service; you will not be able to use this torch until it is repaired by a qualified person.

## Lighting a Torching Trolley

The trigger and pilot valve on a torching trolley operate the same as a hand-held torch. Additionally, torching trolleys often have individual burner valves. Lighting a torching trolley is similar to a hand-held torch:

1. Open each of the individual burner valves fully if so equipped.
2. Slowly open the pilot control to allow a small amount of gas into the burners.
3. Using a spark lighter, individually light each torch head. Start by lighting the torch head farthest from the side where you are standing so you do not need to reach across lit burners.

4. Adjust the pilot control valve to wind conditions so the flames burn steadily.
5. Test the trolley torch operations by operating the trigger valve.
6. Adjust individual burner valves to the job requirements.

Torching trolleys also can be safely lit by passing a lit hand torch across the trolley’s burner heads.

### Torch Assembly Maintenance

As with all equipment used in roofing work, torch assemblies require maintenance. Maintain all roofing torch assembly components as recommended by their manufacturers to ensure you are working with reliable and safe equipment. Inspect equipment daily before use. Tag, remove from service and report any defective equipment to your supervisor.

### Torch System Disassembly

Always disconnect torch assemblies from their propane cylinders at the end of each workday or when removing equipment from the job site.

Lock torch assembly components in suitable containment to prevent overnight damage and theft. Inspect all components for damage and wear before putting them away. Remove damaged components from service. Don’t store damaged components or you may set up an accident for the next user.

Again, refer to the component manufacturer’s instructions before dismantling a torch assembly, and follow these general steps:

1. Set a lit torch down on its stand. Walk to the propane cylinder, and tightly close the valve while the torch is still burning.
2. Return to the torch and squeeze the trigger to burn off remaining gas from the hose.
3. Close all torch valves, and turn the regulator control knob or screw to the closed position.
4. Disconnect the regulator from the cylinder valve. Note: It is possible for a small amount of propane to remain in the hose until the regulator or torch valve is disconnected from the fuel source.
5. For storage longer than 30 days, a torch system should be completely dismantled into its separate components. For shorter-term storage, a hose, torch and regulator may be left assembled after the gas has been purged.

### Safe Torch Application Techniques

There are a few general application safety tips you need to remember when using any torching equipment:

- Propane torch flames are difficult to see in bright sunlight.
- Always assume a torch at rest is lit.
- When you need to set down a hand torch, use its leg stand (see Photo 1). Do not use a torch without an attached, secure leg stand.
- Shut off a torch if you will not be using it for more than two minutes.
- Never leave a lit torch unattended.
- Never operate a torch within 3 feet of another worker.
- Never point a torch flame at an area you cannot clearly see.  
Flashings, corners, curbs, voids, expansion joints and small penetrations in a roof deck may hide combustible materials. *Always implement the torch-and-flop method, cold-applied method or mop-applied method for applications in these areas.*
- Never lay a torch to rest over the edge of a roof, on a coping cap or over a parapet wall.
- Never torch directly to a combustible substrate.
- Never torch directly to adhesives, mastics or cements, such as asphalt-based roof cements, or to wet primers. They are highly flammable.
- Never turn a tank on its side to increase a fuel supply.
- Never apply an open flame to defrost a propane cylinder.

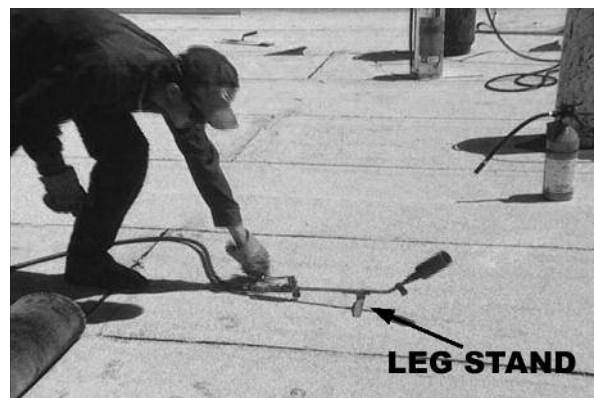

Photo 1: Always set down a hand torch using its leg stand.

## Hand-held Torch Applications

If you are advancing a membrane roll with your foot, you will be behind and facing the roll while pushing the unrolled portion into position as it is being heated (see Photo 2). The rate of application, weather conditions and material type all determine how well a membrane adheres.

Some membrane applications will require you to stand in front of a roll and pull it toward yourself as it is heated. A metal pole with a hook on its end is used to pull the membrane. (Using this hook method necessitates walking backward). This method makes it possible to avoid walking on a finished surface while the membrane is still hot. The pulling method generally is preferred when applying SBS polymer-modified bitumen membranes, which soften at a lower temperature than APP polymer-modified bitumen membranes.

High wind gusts can blow heated membranes, and they may hit and burn you. Minimize this hazard by being aware of the wind direction, applying smaller pieces of material and wearing proper PPE.

## Torching Trolley Application

Torching trolleys provide even heat distribution to a membrane roll so it can be installed more quickly. Using a torching trolley requires you to be in front of and pulling a membrane roll toward yourself while walking backward (see Photo 3). Torching trolleys typically operate at higher gas pressures and consume larger quantities of propane fuel than hand torches. Using a trolley manufacturer's recommended pressure regulator and a larger propane cylinder helps provide for a safer and more trouble-free installation. During high crosswind applications, torching trolleys fitted with a side wind shield can provide improved heat and flame distribution on the membrane.

## Walking Backward on a Roof

As mentioned, using a hook or a torching trolley requires you to walk backward. Walking backward may increase the likelihood of a trip or fall. You must be sure all fall-protection systems are in place and you are using them appropriately, and you also must be aware of what is behind you at all times when walking backward. In addition to fall-protection systems, a second person, or spotter, is recommended to warn you when you are approaching penetrations and perimeter edges.

## Application Quality

Although the NRCA/MRCA CERTA program is primarily a safety program, you also should be mindful of the quality of your workmanship when installing torch-applied membranes. This section provides a few suggestions for keeping your application safe and your workmanship levels high.

### *Handling a Torch*

Direct the torch flame to the underside of a membrane roll. Hold the torch close to the roll without touching it so the heat is applied where the roll meets the substrate surface. Move the hand torch burner flame evenly back and forth across the full face width of the roll. Angle the torch slightly toward the center of the roll when the flame is close to the roll ends. When the bitumen develops a glossy sheen, becomes less viscous and begins to flow, it is properly heated. When using a torching trolley, adjust individual burner heads to provide even heat across the face of a roll.

### *Flame Direction*

The flame from a burner head(s) should be directed at the face of a roll. Some of the heat will curl up toward the top of the roll, and some will curl down, softening the bitumen evenly. How much of a flame you direct at a roll versus a substrate will vary depending on the materials being used and weather conditions.



*Photo 2: A roofing worker is advancing a roll of membrane.*

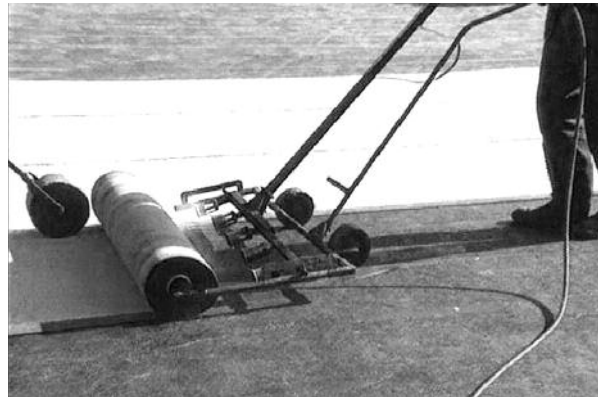

*Photo 3: A roofing worker pulls a torching trolley backward.*

***Advancing a Roll***

As the polymer-modified bitumen begins to soften, advance the roll (approximately 4 to 6 inches) so the next portion of unsoftened material can be heated.

***Bitumen Flow***

As a heated roll is advanced and makes contact with a substrate, a flow of hot bitumen should extend just beyond and be visible at the roll's edges and in front of the roll. This provides a visual indication the heated membrane is bonding properly to the substrate. Adjusting the speed at which you unroll the membrane helps maintain a consistent bitumen flow.

***Quality Control***

There are many other installation details that affect the quality of your workmanship when applying torch-applied membranes. You can read more about these details in the NRCA/ARMA *Quality Control Guidelines for Application of Polymer-modified Bitumen Roofing*.

**Field Membrane Applications*****Thermal Barrier***

If you are torching over a plywood, oriented strand board (OSB), wood plank roof deck or other type of roof deck that you cannot identify as noncombustible without above-deck thermal insulation, incorporate an above-deck thermal barrier into the roof system design before torching. Acceptable thermal barriers include:

- Minimum ¾-inch-thick perlite board insulation
- Minimum ¾-inch-thick fiberglass or mineral wool board insulation
- Minimum ¼-inch-thick glass-faced gypsum board

When a layer of noncombustible insulation is used as a thermal barrier, a roof system shall be considered an “insulated substrate.” It must comply with the manufacturer’s recommendations and specific recommendations for insulation in The NRCA Roofing Manual.

***Base Ply Applications***

Torch-applied polymer-modified bitumen roof system applications require a base ply or plies to be installed prior to the finish surface sheet. A base ply or plies are typically required in the field and at the flashings. When installing field base plies, it is important to extend the base ply or plies vertically a minimum of 3 inches above the cant strip at vertical flashing locations (see Figure 1). This procedure helps reduce fire hazards.

***Field Application Methods***

There are three primary application methods used for polymer-modified bitumen sheet products. These include:

- Mop-applied with hot bitumen
- Cold-adhesive applied
- Torch-applied

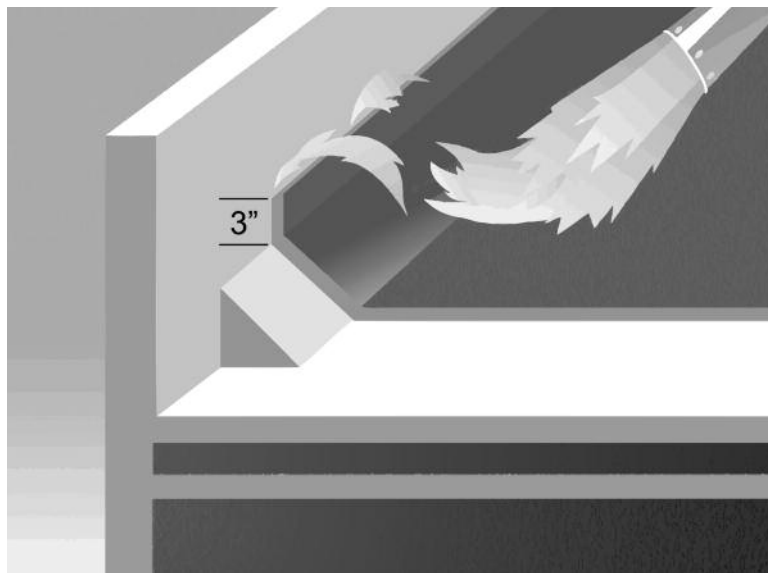

Figure 1: Extend base plies a minimum of 3 inches.

This program focuses on safe torch application methods. Mop-applied and cold-adhesive applied application methods are taught in other training programs. However, you often will need to use these other application methods during torch-applied installations where conditions exist that may present additional hazards, such as when you cannot determine the type of roof deck or flashing substrate. Other NRCA programs provide training about mop-applied and cold-adhesive applied polymer-modified bitumen roof systems.

***Torch and Flop for Field Applications***

The torch-and-flop application method is an effective work practice you can use to minimize the risk of fire when using a torch. Torch-and-flop methods can be used wherever fire hazards exist on a roof, including all perimeter edges, walls and penetrations.

Other safety practices, such as adding a thermal barrier or using the torch-and-flop method, should always be used if you cannot identify any materials in the field substrate. There are two primary torch-and-flop methods: one for field applications and one for flashing applications.

When you are starting a roll or ending the membrane field ply at a wall or roof edge or when approaching a penetration, the torch-and-flop method, cold-applied method or mop-applied method can be used. Following are step-by-step procedures for proper torch-and-flop application at these roof areas. Remember, as for all roofing work, the first step always is wearing appropriate PPE.

#### Starting field membranes at roof edges or walls:

1. Roll the membrane out 6 to 10 feet, and position the roll so it runs straight. Allow specified distances for turning up a wall or over an edge.
2. Standing on the membrane to hold it in position, lift and pull the membrane back away from the wall or roof edge and lay it down back over itself.
3. Direct a torch flame onto the exposed back side of the membrane until it is evenly and thoroughly heated. Be careful not to extend the flame past the roll edges so underlying sheets are not damaged. Never allow an open flame to reach an edge or a wall.
4. Use a trowel to lift the heated membrane enough for you to grip the sheet firmly. Lift the heated membrane, and let it loosely roll and flop into place.
5. Immediately step-in or broom-in the sheet to bond it in place, then roll or trowel the lapped seams to achieve required bleedout.

#### Ending field membranes at roof edges or walls:

1. Stop advancing the roll's torch application before reaching a wall or roof edge.
2. Dry-roll the membrane to the wall or edge without torching, and cut the roll to length. Allow specified distances for turning up the wall or over the edge.
3. Lift and pull back the dry membrane to the point it is bonded, and lay it back down over itself.
4. Direct the torch flame onto the exposed back side of the membrane until it is evenly and thoroughly heated. Be careful not to extend the flame past the roll edges so underlying sheets are not damaged. Never allow an open flame to reach an edge or a wall.
5. Use a trowel to lift the heated membrane enough for you to grip the sheet firmly. Lift the heated membrane, and let it loosely roll and flop into place.
6. Immediately step-in or broom-in the sheet to bond it in place, then roll or trowel the lapped seams to achieve required bleedout.

#### Around penetrations:

1. Stop advancing the roll's torch application before reaching a penetration.
2. Lift and unroll the roll backward over itself, exposing the underside of the membrane, a distance far enough that—when rolled back in place—the sheet will extend past the penetration.
3. Lift the roll again and pull the unrolled portion forward beyond the penetration without heating the sheet in place.
4. Set the roll down, laying the sheet over or up against the penetration.
5. Cut the membrane to dry-fit around the penetration. Again, allow for specified distances for turning up vertical surfaces. You may have to slice the membrane on the up-slope side to fit around the penetration.
6. For interior roof drains, cut a small hole over a drain center and cut finger cuts before heating the membrane. If system specifications allow the use of a target sheet for interior drain flashings, complete this flashing installation before installing the field membrane (see the following section, Flashing Membrane Applications).
7. Lift the roll and pull it backward over itself, again exposing the underside of the membrane, to the point the membrane was previously bonded to the substrate.
8. Direct the torch flame onto the exposed backside of the membrane until it is evenly and thoroughly heated. Be careful not to extend the flame past the roll edges so underlying sheets are not damaged. Never allow an open flame to reach an opening or a penetration.

9. Use a trowel to lift the heated membrane enough for you to grip the sheet firmly. Lift the heated membrane and let it loosely roll and flop into place, guiding it around the penetration.
10. Immediately step-in or broom-in the sheet to bond it in place, then roll or trowel the lapped seams to achieve required bleedout.

## Flashing Membrane Applications

Applying torch-applied, polymer-modified bitumen sheet products as membrane flashings typically requires an approved backer layer be installed over combustible flashing substrates prior to the membrane application. See NRCA/MRCA CERTA Safety Practices for Roofing Torch Use on page 2 for acceptable backer layer configurations.

### *Backer Layer Application*

When installing backer layers over combustible flashing substrates, it is critical that the application results in an air-impermeable installation. Air-impermeable means that no air can pass through the installed membrane. During cold weather or windy conditions, this may require pre-heating a backer layer using a similar torch-and-flop application method as described in the upcoming Torch and Flop for Flashing Application section. You also may need to enhance the application at inside and outside corners using small football-, T-bone- or peanut-shaped pieces of membrane to ensure these vulnerable areas are well-sealed.

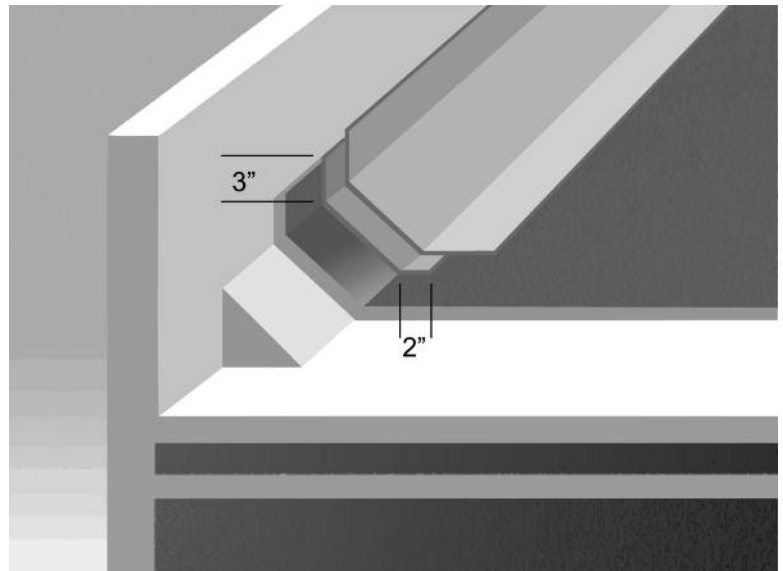

Figure 2: Extend backer layer 3 inches vertically and 2 inches horizontally.

There are four methods used to apply polymer-modified bitumen sheet products as membrane flashings. They include adhering the flashing membrane using cold-applied adhesives; mopping in place using hot bitumen; direct torching; and indirect torching using the torch-and-flop method. This section addresses only the direct torching and indirect torch-and-flop methods.

Recommended backer layer applications include extending the backer ply(ies) horizontally a minimum 2 inches beyond the front edge of the cant. A backer layer should also extend vertically a minimum 3 inches above the top edge of the cant (see Figure 2). Refer to the manufacturer's instructions and The NRCA Roofing Manual for more information.

### *Direct Torching Flashing Application*

When direct torching methods are preferred, only a single-burner, low-output (105k Btu or less) detail torch may be used.

### *Torch and Flop for Flashing Applications*

When installing roof system flashings at walls, perimeter edges or penetrations, the torch-and-flop method may be used. Following are step-by-step procedures for proper torch-and-flop flashing applications. Again, wearing the appropriate PPE is your first step with every flashing installation.

#### At walls, penetrations and perimeter edges:

1. Measure and cut a flashing piece to fit the detail before lighting the torch. Make all corner fold cuts, finger cuts and wing cuts by holding the flashing strip in the place where it will be installed. A maximum length of 1 meter (the width of a roll) is recommended for any individual flashing piece.
2. Position the cut flashing piece upside down and alongside where it will be installed. Keep the flashing piece back from the wall, penetration or edge. Placing a thermal barrier under the cut flashing piece first, such as a piece of ¼-inch glass-faced gypsum board, can help protect installed underlying membranes.
3. Direct a torch flame onto the exposed backside of the flashing piece until it is evenly and thoroughly heated. Be careful not to extend the flame past the edges so underlying sheets are not damaged. Never allow an open flame to reach a wall, penetration or perimeter edge.
4. Use the tip of a trowel to lift the heated membrane enough for you to grip the flashing piece firmly. Lift the heated piece, and flop it into place.
5. Immediately hand-press the flashing piece to bond in place, and trowel lap seams to achieve required bleedout.

## Application Hazard Recognition

Section 2, Pre-job Planning and Preparation, of this student manual introduced several hazards you should look for during a pre-job inspection. Your foreman or supervisor should discuss any hazards and how they are to be addressed with all crew members before starting torching operations. Your job is to recognize hazards while using a torch in these areas and know what to do in each situation to keep safe. The following exercise is designed to help you recognize and understand what makes each hazard so dangerous.

### Hazard Recognition Exercise

#### INSTRUCTIONS:

On the following pages are 12 images representing common fire hazards found while installing torch-applied roof systems. You and your team have 30 minutes to discuss each picture and complete the exercise. Write answers clearly for each step so you can refer to them later. Hazard 1 is completed for you as an example. Your instructor will review all the answers with the entire class.

**Step 1:** Identify the type of hazard by writing its corresponding letter from the following list of categories. Write all possible categories for each hazard.

- A. Combustible roof deck
- B. Combustible or flammable materials below the roof deck
- C. Combustible flashing substrates
- D. Combustible adjacent building components
- E. HVAC service lines or utility pipes
- F. Rooftop penetrations
- G. Flammable or explosive vapors or gases
- H. Rooftop mechanical equipment
- I. Additional wall or flashing components
- J. Perimeter edges

**Step 2:** After looking at an image, describe in line 2 how you think a fire could start when using a torch near the hazard.

**Step 3:** List on line 3 as many actions as you can think of taking when handling a torch that would help avoid starting a fire near the hazard.

**Step 4:** The roof plan on page 45 contains all the hazards presented in this exercise. Write the corresponding hazard type on the arrows pointing to each hazard.



**HAZARD 1**

1. Category of hazard: **A, B, C, F, G, H**

2. Description: Flames could ignite combustible deck or flashing materials, get sucked inside of building and ignite something below, or ignite exhaust fumes or vapors.

3. List of actions: Check with building owner to see whether this is an intake vent or exhausting vapors and needs to be shut down. Never direct an open flame at the vent. Be sure flashings have an approved backer layer installed, and use the mop-applied method, cold-applied method or torch-and-flop method.

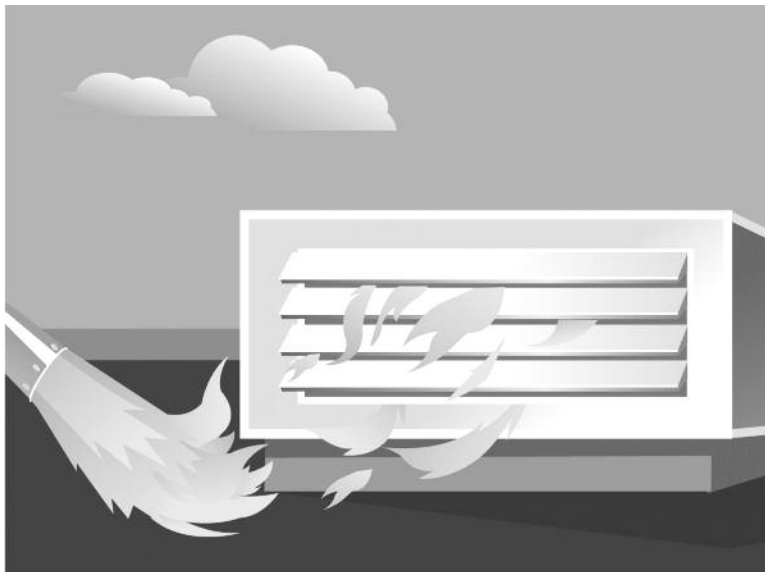

**HAZARD 2**

1. Category of hazard: \_\_\_\_\_

2. Description: \_\_\_\_\_

\_\_\_\_\_

\_\_\_\_\_

3. List of actions: \_\_\_\_\_

\_\_\_\_\_

\_\_\_\_\_



**HAZARD 3**

1. Category of hazard: \_\_\_\_\_

2. Description: \_\_\_\_\_

\_\_\_\_\_  
\_\_\_\_\_

3. List of actions: \_\_\_\_\_

\_\_\_\_\_  
\_\_\_\_\_



**HAZARD 4**

1. Category of hazard: \_\_\_\_\_

2. Description: \_\_\_\_\_

\_\_\_\_\_  
\_\_\_\_\_

3. List of actions: \_\_\_\_\_

\_\_\_\_\_  
\_\_\_\_\_



**HAZARD 5**

1. Category of hazard: \_\_\_\_\_

2. Description: \_\_\_\_\_

\_\_\_\_\_  
\_\_\_\_\_

3. List of actions: \_\_\_\_\_

\_\_\_\_\_  
\_\_\_\_\_



**HAZARD 6**

1. Category of hazard: \_\_\_\_\_

2. Description: \_\_\_\_\_

\_\_\_\_\_  
\_\_\_\_\_

3. List of actions: \_\_\_\_\_

\_\_\_\_\_  
\_\_\_\_\_



**HAZARD 7**

1. Category of hazard: \_\_\_\_\_

2. Description: \_\_\_\_\_

\_\_\_\_\_  
\_\_\_\_\_

3. List of actions: \_\_\_\_\_

\_\_\_\_\_  
\_\_\_\_\_

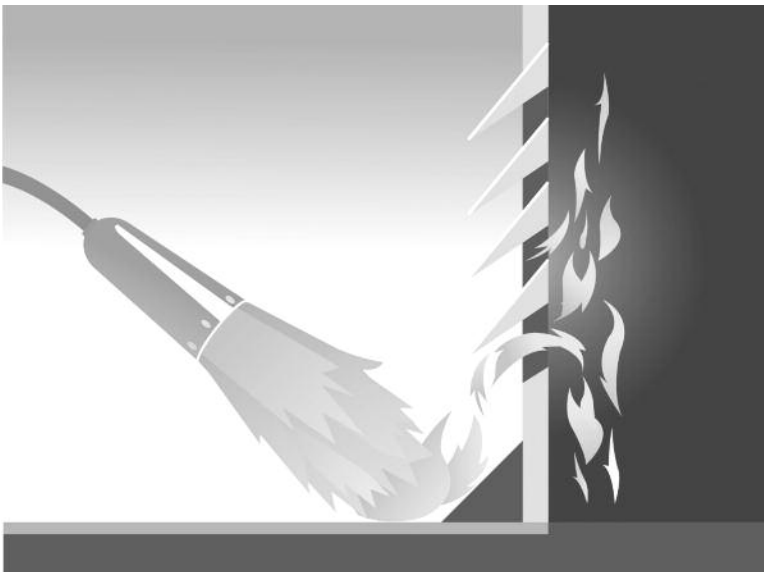

**HAZARD 8**

1. Category of hazard: \_\_\_\_\_

2. Description: \_\_\_\_\_

\_\_\_\_\_  
\_\_\_\_\_

3. List of actions: \_\_\_\_\_

\_\_\_\_\_  
\_\_\_\_\_

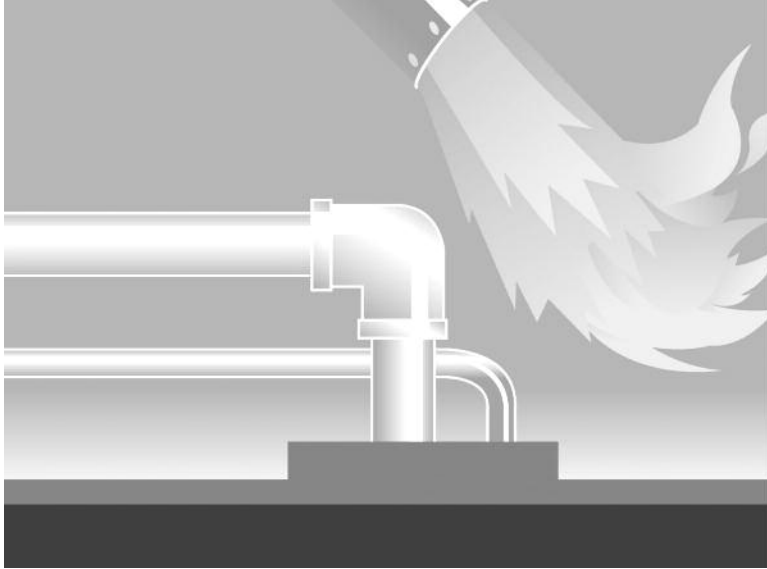

**HAZARD 9**

1. Category of hazard: \_\_\_\_\_

2. Description: \_\_\_\_\_

\_\_\_\_\_  
\_\_\_\_\_

3. List of actions: \_\_\_\_\_

\_\_\_\_\_  
\_\_\_\_\_



**HAZARD 10**

1. Category of hazard: \_\_\_\_\_

2. Description: \_\_\_\_\_

\_\_\_\_\_  
\_\_\_\_\_

3. List of actions: \_\_\_\_\_

\_\_\_\_\_  
\_\_\_\_\_

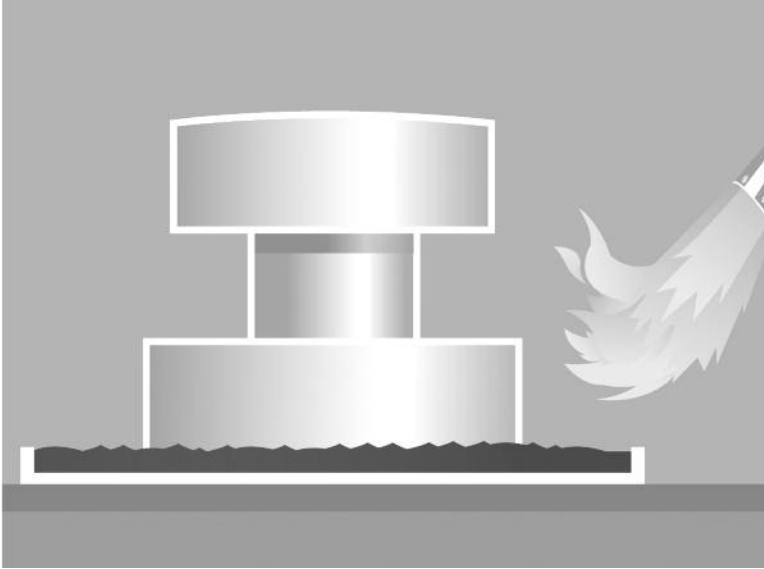

**HAZARD 11**

1. Category of hazard: \_\_\_\_\_

2. Description: \_\_\_\_\_

\_\_\_\_\_  
\_\_\_\_\_

3. List of actions: \_\_\_\_\_

\_\_\_\_\_  
\_\_\_\_\_

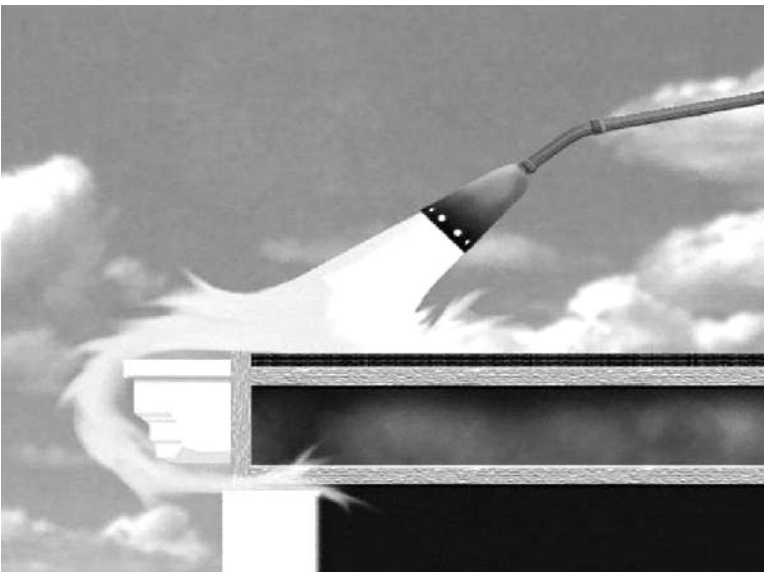

**HAZARD 12**

1. Category of hazard: \_\_\_\_\_

2. Description: \_\_\_\_\_

\_\_\_\_\_  
\_\_\_\_\_

3. List of actions: \_\_\_\_\_

\_\_\_\_\_  
\_\_\_\_\_

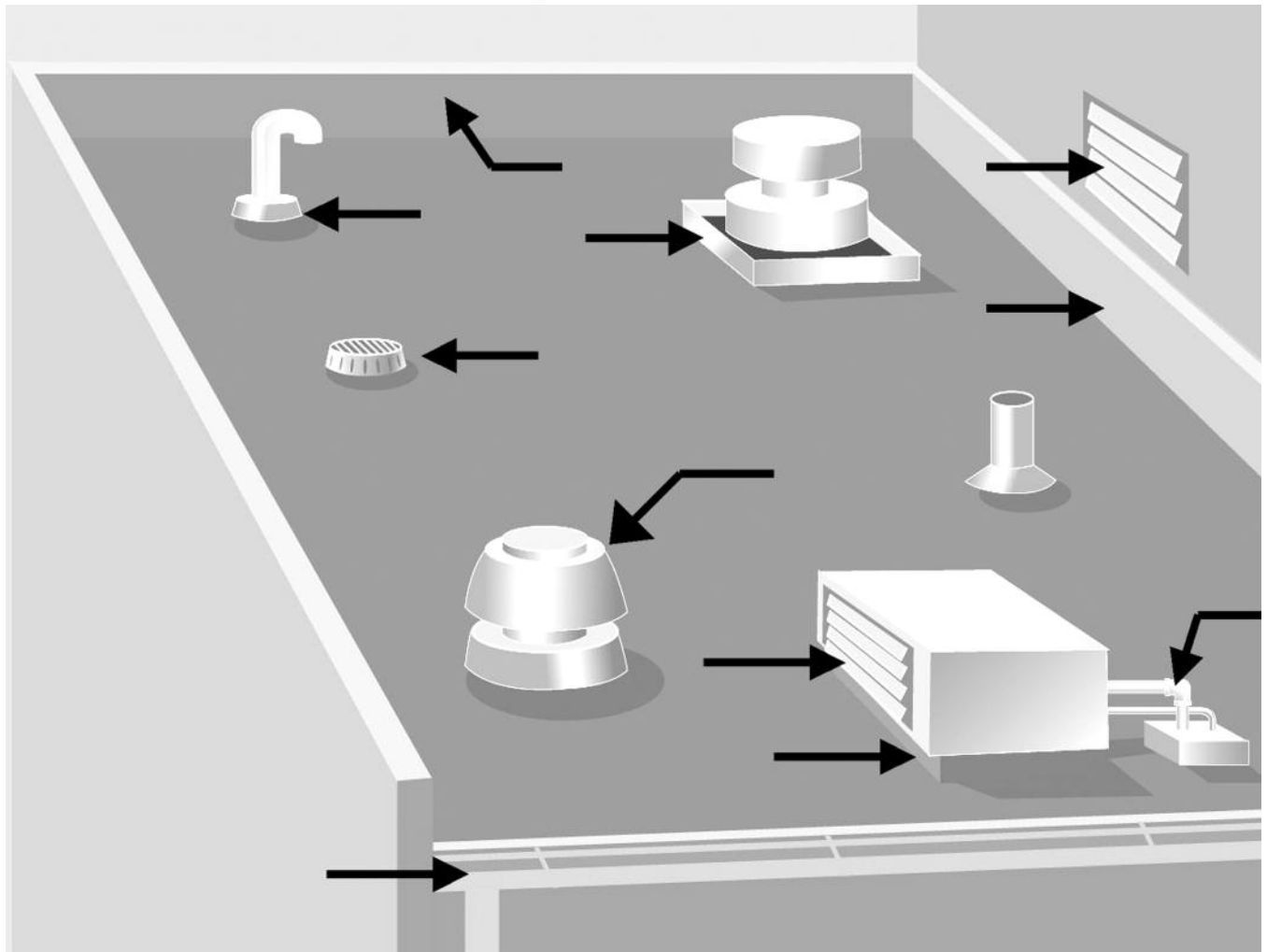

**TYPES OF HAZARDS**

- A. Combustible roof deck
- B. Combustible or flammable materials below the roof deck
- C. Combustible flashing substrates
- D. Combustible adjacent building components
- E. HVAC service lines or utility pipes
- F. Rooftop penetrations
- G. Flammable or explosive vapors or gases
- H. Rooftop mechanical equipment
- I. Additional wall or flashing components
- J. Perimeter edges

## ASSEMBLING A ROOFING TORCH ASSEMBLY

Step Number	Action
	Open the propane cylinder valve fully while the regulator adjustment valve is still closed. Slowly open the regulator adjustment valve just enough to blow out any foreign matter. Close both valves.
	Attach the regulator to the cylinder valve. Tighten the connection.
	Inspect all equipment for damage.
	Conduct a leak test.
	Tightly close the cylinder valve handle and regulator adjustment valve using its knob or screw.
	Assemble a roofing torch following its manufacturer’s instructions. Attach the other hose end to the roofing torch.
	Attach the hose end connector to the regulator. Tighten the hose fitting snugly to the regulator outlet.
	Inspect the cylinder valve for dirt or foreign substances. Clean it out with a clean rag or soft brush if necessary. Use compressed air to blow out any foreign material that may have accumulated during storage.

# Section 5 POST-JOB REQUIREMENTS AND DUTIES

---

Most serious roof fires caused by the use of torches occur hours after the roofing crew has gone home at the end of a day. Combustible materials often ignite while the crew is working and then smolder unnoticed beneath the roof system, building up heat until they burst into flames several hours later. But a smoldering fire can be detected, however, if you know what to look for. This section addresses how to look for smoldering fires and other duties to perform after the last torch is extinguished on a job.

## Post-job Fire Watch

### Fire Watch—Definition

A fire watch is just what its name implies: the act of watching for a fire. A person designated to conduct a fire watch must be competent and have authority to take action in the event a fire is detected. A competent person is someone who has the necessary experience or training to identify existing or predictable hazards on the work site and who has the authorization to take prompt corrective measures to eliminate them. The designated competent person performs fire-watch duties throughout each workday and, in addition, a minimum two-hour period starting when the last torch is extinguished on a roof. If the torching activity is performed by a repair crew, a focused fire watch should be conducted in the general repair area.

The following table describes a fire-watch duty, what to look for, how to find fire, and when or how often to conduct each specific duty.

	DUTY	WHAT TO LOOK FOR	HOW TO FIND FIRE	WHEN TO COMPLETE DUTY
1.	Regular underside inspections of visibly open combustible roof decks	Discolored or unusual appearance of deck materials (glazed look, yellowish or brownish color, dripping liquids, etc.) - Blistered paint - Smoke - Glowing embers	- Focus under perimeters and penetrations. - Use a flashlight if necessary.	Three or four times daily (during crew breaks, lunch, etc.)
2.	Regular inspections of concealed attic areas under all types of roof decks	- All items in Duty 1 - Light penetrating from outside - Unusual or burning odors	- Visually inspect all areas using a strong-beamed flashlight (it helps detect smoke). - Smell intentionally.	Inspect every two hours or as agreed with the building owner.
3.	Regular inspections of the roof's entire field and all flashings	- Discolored or unusual appearance of surface membrane, insulation or deck (darker color, glazed look, etc.) - Smoke - Sagging surfacing materials or bitumen on vertical flashings - Unusual or burning odors - Surfaces are warm to the touch.	- Visually inspect all roof areas. - Use an infrared heat detector. - Smell intentionally. - Feel around perimeters and all flashings of the daily work area. -Use an infrared heat detector.	Ongoing throughout workday in rotation with Duty 2.
4.	Two-hour inspection of the roof's entire field, all flashings, and underside of visibly open roof decks and concealed attic areas	All items included in Duties 1, 2 and 3	All items included in Duties 1, 2 and 3	Complete inspection tasks continuously throughout the entire two-hour period.

## Conducting a Fire Watch

A two-hour fire watch begins as soon as the last torch on the roof is extinguished. Other crew members may continue with tasks, such as storing propane cylinders and equipment or cleaning up the job site. But a competent person performing a fire watch should have no other duties.

If you are designated to perform the fire watch, start by inspecting a building's interior and roof deck's underside and concealed attic areas. Next, return to the roof and concentrate on hazard areas most susceptible to concealing smoldering materials, including penetrations, perimeter edges and all flashing areas. Use your bare hand to feel around these areas for hot spots, or use an infrared heat detector. Be alert for unusual odors. Continue inspecting the open field of the roof and, if possible, check the interior of the building once more before leaving.

The area of a smoldering fire can be extensive. If smoldering fire is suspected, immediately call the fire department. Next, evacuate the building. Do not try to rip open a roof area to extinguish a fire yourself.

Document completion of each fire watch. This written record should include the time it was started and completed, details of restarting mechanical equipment, areas inspected, and all communications with the building owner or the owner's representative.

## Building Owner Requirements

Performing fire-watch duties requires active communication and cooperation with a building owner or his or her representative.

If you are the designated competent person for fire-watch duty, you will need to know the location of the building's fire alarm, as well as how to operate it. You also must be given authority by the building owner to trigger an alarm in the event of a fire.

Interior inspections require easy access throughout the day for viewing the underside of the roof deck or inspecting concealed attic areas. Identify access points with the building owner, and discuss the frequency a competent person may perform interior fire-watch duties. Realize that after-hours access for interior inspections is a key fire-watch requirement.

Building system mechanical equipment shutdown before torching activities—such as air intakes, sawdust collectors, lint traps or exhaust vents—may require restarting after roofing work is completed each day. Only the building owner should authorize the designated competent person to schedule equipment restart at the end of a day. Before restarting any mechanical equipment, the equipment curbs, filters, ducts and immediate roof deck should be inspected to ensure there are no smoldering materials or hot spots present. Starting equipment will increase air flow and possibly accelerate fire ignition. Never authorize equipment restart before completing focused fire-watch inspections in these areas.











Roofing contractors should discuss these requirements in detail with building owners before work begins.

## Other Post-job Requirements and Duties

Torching work requires a few safety-related tasks be performed in addition to typical end-of-day roofing job-site tasks. Although specific duties will vary from job to job, a few common tasks are required for all torching work. Section 2, Pre-job Planning and Preparation, addresses pre-job inspections and checklist use. It is helpful to include the following post-job requirements as parts of the checklist to document these important tasks are done. Post-job tasks include:

- Storing torch assembly components in a secure area
- Checking that all propane cylinder valves are securely turned off
- Removing cylinders from the roof for overnight storage if practical. If not practical, gather all cylinders near the center of the roof away from combustible materials, penetrations, walls and roof edges.
- Securing all cylinders upright in a group using steel wire, heavy chain or a binder strap
- Cleaning and removing loose combustible materials and debris

## TEN FIRE-WATCH AND POST-JOB BASICS

1. Most serious roof  caused by torches happen \_\_\_\_\_ the crew has gone home.
2. Combustible materials can ignite during the day and not be noticed because they are  \_\_\_\_\_ the roof system.
3. The person who conducts a fire  must be competent and have authority to take \_\_\_\_\_.
4. The designated  performs fire-watch duty throughout each work \_\_\_\_\_.
5. In addition, a \_\_\_\_\_-hour fire watch begins as soon as the last  on the roof is extinguished. The fire watch may take longer, depending on conditions.
6. A competent person performing fire-watch duty must know where a building's  is and know how to \_\_\_\_\_ it.
7. He or she must also have authority by the  owner to \_\_\_\_\_ the alarm.
8. Interior inspections require easy access for viewing the underside of the roof deck or inspecting concealed attic areas. \_\_\_\_\_-\_\_\_\_\_ access for interior inspections is a  fire-watch requirement.
9. Post-job tasks include  that all cylinder \_\_\_\_\_ are turned off.
10. Remove cylinders from the roof for overnight storage if you can. If not, gather all cylinders near the center of the roof away from \_\_\_\_\_ materials, penetrations, walls and roof edges. Secure cylinders upright in a group using steel wire, heavy  or a binder strap.

# APPENDIX | REFERENCE MATERIALS

## Related Industry Organizations

### **Compressed Gas Association (CGA)**

4221 Walney Road, Fifth Floor  
Chantilly, VA 20151-2923  
(703) 788-2700 Fax: (703) 961-1831  
E-mail: [cga@cganet.com](mailto:cga@cganet.com)  
Web site: [www.cganet.com](http://www.cganet.com)

### **FM Approvals (FM)**

1151 Boston-Providence Turnpike  
Norwood, MA 02062  
(781) 762-4300 Fax: (781) 762-9375  
Web site: [www.fmglobal.com](http://www.fmglobal.com)

### **Midwest Roofing Contractors Association (MRCA)**

4700 W. Lake Ave.  
Glenview, IL 60025  
(847) 375-4748 Fax: (847) 375-6473  
E-mail: [mrca@mrca.org](mailto:mrca@mrca.org)  
Web site: [www.mrca.org](http://www.mrca.org)

### **National Fire Protection Association (NFPA)**

1 Batterymarch Park  
Quincy, MA 02169-7471  
(617) 770-3000 Fax: (617) 770-0700  
E-mail: [custserv@nfpa.org](mailto:custserv@nfpa.org)  
Web site: [www.nfpa.org](http://www.nfpa.org)

### **National Propane Gas Association (NPGA)**

1150 17th St. NW, Suite 310  
Washington, DC 20036-4623  
(202) 466-7200 Fax: (202) 466-7205  
E-mail: [info@npga.org](mailto:info@npga.org)  
Web site: [www.npga.org](http://www.npga.org)

### **National Roofing Contractors Association (NRCA)**

10255 W. Higgins Road, Suite 600  
Rosemont, IL 60018-5607  
(847) 299-9070 Fax: (847) 299-1183  
E-mail: [nrca@nrca.net](mailto:nrca@nrca.net)  
Web site: [www.nrca.net](http://www.nrca.net)

### **Occupational Safety and Health Administration (OSHA)**

U.S. Department of Labor  
200 Constitution Ave. NW  
Washington, DC 20210  
(800) 321-OSHA  
Web site: [www.osha.gov](http://www.osha.gov)

### **Underwriters Laboratories (UL)**

333 Pfingsten Road  
Northbrook, IL 60062-2096  
(847) 272-8800 Fax: (847) 272-8129  
E-mail: [northbrook@ul.us.com](mailto:northbrook@ul.us.com)  
Web site: [www.ul.com](http://www.ul.com)

## Glossary

**ABC fire extinguisher:** A pressurized steel cylinder filled with fire-extinguishing powdered chemicals useful for extinguishing types A (combustibles), B (gas and liquids) and C (electrical) fires. Two minimum 4A60BC fire extinguishers are recommended for torching work.

**air-impermeable:** Not permitting the passage of air through a substance.

**CGA:** Compressed Gas Association.

**check valve:** A spring-loaded diaphragm valve built into some cylinder valves designed to permit gas flow only under preset conditions.

**combustible:** Capable of burning.

**combustion:** An act or instance of burning.

**competent person:** A person who is capable of identifying existing or predictable fire hazards in the surroundings or working conditions and who has authorization to take prompt corrective measures to eliminate them, such as calling the fire department or evacuating a building.

**cylinder:** A cylindrical-shaped tank fabricated of steel or aluminum for containing pressurized liquefied petroleum gas; also called a bottle or tank.

**cylinder cart:** A specially designed frame on wheels used to store and transport propane cylinders. A chain or strap is used to secure tanks to the frame.

**cylinder valve:** The on/off valve on a propane tank.

**direct torching:** A term used to describe using the direct flame of a torch to heat torch-applied polymer-modified bitumen into place.

**dip tube:** A pipe extending to the bottom of a cylinder to draw liquid fuel.

**DOT:** Department of Transportation. Note: Contact individual state departments of transportation for your specific transportation needs.

**ethyl mercaptan:** A chemical additive that gives liquefied petroleum gas a distinctive rotten egg odor.

**fire watch:** A daily inspection of building components that lasts at least two hours after open-flame torching work has ceased; intended to identify unseen smoldering materials.

**fixed-length dip tube gauging device:** A small tube inside a vapor cylinder that releases liquid propane when a cylinder is 80 percent full; often called a spit valve or outage gauge.

**flammable:** Easily ignited and combusts rapidly.

**flint lighter:** Manually operated tool that uses friction between flint and coarse metal to create a spark used for safely igniting liquefied petroleum gas; also called a spark lighter or striker.

**FM Approvals:** An independent organization relating to the insurance industry that tests building materials to assess performance, including wind and fire resistance.

**foot ring:** A metal ring welded to the bottom of a cylinder allowing it to stand on end.

**fuel gas:** See “liquefied petroleum gas.”

**liquefied petroleum gas (LP gas or LPG):** Petroleum gas (such as propane, butane or isobutene) compressed to a liquefied state; also referred to as fuel gas.

**liquid-withdrawal system:** A torch assembly utilizing a dip tube in the cylinder to withdraw and deliver liquid liquefied petroleum gas to go to the torch.

**LP gas hose:** A flexible rubber- or plastic-coated hose designed to withstand high pressures used to carry gas from a cylinder to a torch.

**NFPA:** National Fire Protection Association.

**NPGA:** National Propane Gas Association.

**OSHA:** Occupational Safety and Health Administration, a government agency with the authority to establish and enforce regulations pertaining to worker safety.

**pilot control valve:** A torch-handle valve used to regulate propane gas flow to a torch-head pilot flame.

**POL connector:** Counterclockwise (left-handed) threaded male fitting connecting a cylinder valve to a regulator (found only in vapor-withdrawal systems).

**pooling:** The tendency of heavier-than-air gas to seek and remain in low-lying areas.

**pressure gauge:** Gauge used to measure the pressure in pounds per square inch (psi) of regulated liquefied petroleum gas.

**protective collar or cap:** Protective metal shield, welded or screwed around a cylinder valve.

**psi:** Pounds per square inch.

**psia:** Pounds per square inch: absolute.

**psig:** Pounds per square inch gauge.

**purging:** The act of cleaning out a cylinder before filling it with liquefied petroleum gas.

**red label:** A label marking flammable materials.

**red tag:** A tag used to identify a defective piece of equipment that is not in service.

**regulator:** A device used to control liquefied petroleum gas pressure.

**round-nosed trowel:** A rounded-tip trowel designed to not damage a modified bitumen membrane.

**safety relief valve:** A valve mechanism that releases liquefied petroleum gas from a cylinder when the pressure exceeds a preset limit.

**smoldering:** Slowly burning with little smoke and no flame.

**tare weight (T.W.):** Weight of an empty cylinder, marked on its collar.

**torch and flop:** A term used to describe heating, lifting and flopping torch-applied polymer-modified bitumen sheet products into place (as opposed to rolling them out).

**torch assembly:** An assembled torch, hose and regulator coupled to a fuel gas source.

**torching trolley:** A wheeled metal frame that positions, holds and heats a roll of polymer-modified bitumen with four to seven torch heads.

**torch valve:** Gas control knob on torch handles.

**Underwriters Laboratories (UL) Inc.:** An independent testing laboratory that tests building materials to establish performance standards, including wind and fire resistance.

**vapor-withdrawal system:** A system that withdraws and burns vapor collected above liquefied gas in a tank.

**water capacity (W.C.):** Weight of a cylinder full of water, marked on its collar.

## Determining Propane Vaporization Capacities

Copied with permission from *REGO Products LP Gas Serviceman's Manual*

### “Rule of Thumb” Guide for ASME LP Gas Storage Containers

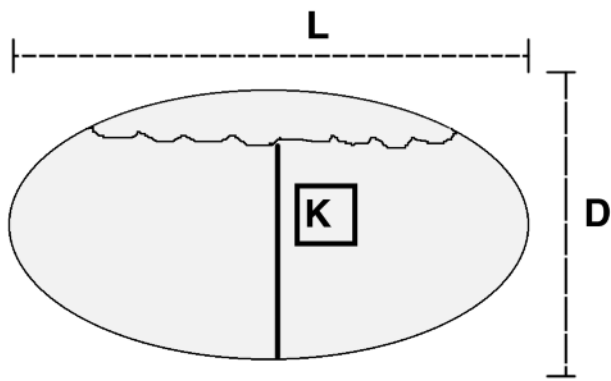

“D” = Outside diameter  
(in inches)

“L” = Overall length  
(in inches)

“K” = Constant for percent  
volume of liquid in  
container

Percentage of Container Filled	K Equals	*Propane Vaporization Capacity at 0 F. (In Btu/Hr)
60	100	$D \times L \times 100$
50	90	$D \times L \times 90$
40	80	$D \times L \times 80$
30	70	$D \times L \times 70$
20	60	$D \times L \times 60$
10	45	$D \times L \times 45$

*\*These formulas allow for the temperature of the liquid to refrigerate to -20 F, producing a temperature differential of 20 degrees for the transfer of heat from the air to the container’s “wetted” surface and then into the liquid. The vapor space area of the vessel is not considered. Its effect is negligible.*

### Vaporizing Capacities for Other Air Temperatures

Multiply the results obtained with the above formulas by one of the following factors for the prevailing air temperature.

Prevailing Air Temperature	Multiplier
- 15 F	0.25
- 10 F	0.50
- 5 F	0.75
0 F	1.00
+ 5 F	1.25
+ 10 F	1.50
+15 F	1.75



**Certified Roofing Torch Applicator Training Program**

**Daily Inspection Checklist**

<b>Inspection Date:</b>			
<b>Project Name:</b>			
<b>Address:</b>			
<b>Roof Deck Type:</b> _____			
<input type="checkbox"/> underside exposed <input type="checkbox"/> underside concealed			
<b>Fire Department Telephone Number:</b>			
<b>Police Department Telephone Number:</b>			
<b>Building Owner's Name:</b>			
<b>Building Owner's After-hours Telephone Number:</b>			
<b>Pre-job Inspection</b>			
√	<b>HAZARDS AND CONDITIONS</b>	<b>Actions Taken</b>	<b>Initials</b>
<b>General Conditions</b>			
	Job-site housekeeping		
	Exposed roof edges		
	Equipment and hose organization		
	Low or poorly ventilated roof areas		
	Changed conditions since previous day (e.g., combustible or flammable materials stored by building owner)		
	Wind conditions		

<b>Fire Safety</b>		Specific codes discussed:	
	Local building codes and regulations		
Official's name:			
Date contacted:			
Official's telephone number:			
	Job-site no-smoking signs	Posted locations:	
Fire extinguishers			
	Type 4A60BC		
	Quantity		
	Inspection dates		
	Plastic seals		
	Pressure		
	Location relative to torching		
	Location relative to cylinders		
	Emergency telephone numbers posted		
Posted locations:			
	Combustible roof deck	Deck type:	
	Combustible materials below roof deck		
Locations:			
Combustible flashing substrates			
	Cant strips type: _____		
	Wood nailers		
	Flashing substrate type: _____		
Adjacent combustible building components			
	Door thresholds		
	Siding materials		
	Window sills		
	Other		

Concealed attic or crawl space areas			
	Access: _____ _____ _____		
	HVAC or utility service lines		
Rooftop mechanical equipment			
	Wall louvers		
	Air intakes		
	Exhaust vents		
	Lint or sawdust collectors		
	HVAC units		
	Air-filtering units		
	Water chillers		
	Condensing units		
	Other equipment		
Wall or flashing components			
	Counterflashings		
	Coping caps		
	Through-wall scuppers		
	Others		
Perimeter edges			
	Gravel stop		
	Gutter		
	Drip edge		
	Other		
<b>In-progress Inspections</b>			
Unattended torches			
	Shut off		
	Lit		
Under-deck inspections access locations (include concealed attic areas)		Inspection times: <b>A.M.</b>	Inspection times: <b>P.M.</b>

<b>Post-job Inspections and Tasks</b>		
<b>Fire Watch</b>		Ongoing from ____:____ a.m./p.m. to ____:____ a.m./p.m.
Under-deck inspections access locations (include concealed attic areas)		Inspection times
Rooftop inspections		Inspection times
Open field of roof		
<b>Rooftop mechanical equipment (list)</b>		
<b>Walls and flashing components (list)</b>		
<b>Perimeter edges (list)</b>		
<b>LP Gas Cylinder Storage</b>		
All cylinders stored		Location (ground or roof area):
Grouped together		
Secured		Method used:
Cylinder valves tightly shut off		
<b>Torching Equipment</b>		
Inspected for damage		
All equipment stored		Location:
Other		
Other		

## Hands-on Performance Evaluation Form

### Instructions for Evaluating Torch Operators

Observe the torch operator as he or she performs each step of the exercise. Circle the number you feel represents how well the operator performed on each step. Keep in mind that everyone uses a torch differently, so please only base your scores on the way each step is described.

**Scoring:**      1          2          3  
                          Poor      Fair      Excellent

STEP	SCORE		
<b>Lighting a torch</b>			
wears proper PPE	1	2	3
closes all valves and opens regulator	1	2	3
points torch away from himself or herself and others	1	2	3
slowly opens cylinder valve	1	2	3
adjusts regulator to proper pressure setting	1	2	3
slowly opens pilot valve	1	2	3
uses a spark lighter	1	2	3
adjusts pilot valve	1	2	3
tests torch operation using trigger	1	2	3
<b>Flashing box stations 1 and 2: flashing torch and flop</b>			
wears proper PPE	1	2	3
installs a self-adhering backer ply with sealed laps, extending a minimum of 2 inches onto field	1	2	3
measures and pre-cuts flashing strips	1	2	3
positions cut flashing strip upside down away from box curb	1	2	3
evenly heats back of flashing strips without damage to substrate	1	2	3
lifts flashing strip with trowel, grips it and flops it into place	1	2	3
presses flashing firmly into place	1	2	3
<b>NEVER TOUCHES THE FLASHING BOX WITH A FLAME</b>	1	2	3
<b>Field mock-up stations 3 and 4: starting field membranes at roof edges or walls</b>			
wears proper PPE	1	2	3
rolls membrane out 6 to 10 feet and positions in place	1	2	3
stands on roll and flops membrane back	1	2	3
evenly heats back of membrane without damage to substrate	1	2	3
lifts membrane with trowel, grips it and flops it into place	1	2	3
steps membrane in place and trowels lapped seam	1	2	3
<b>NEVER TOUCHES THE WALL OR EDGE WITH A FLAME</b>	1	2	3
<b>Field mock-up stations 3 and 4: installing target sheet at drain</b>			
wears proper PPE	1	2	3
measures and pre-cuts target sheet including finger cuts	1	2	3
positions cut target sheet upside down away from drain opening	1	2	3
evenly heats back of target sheet without damage to substrate	1	2	3

lifts target sheet with trowel, grips it and flops it into place	1	2	3
presses target sheet firmly into place with trowel	1	2	3
<b>NEVER TOUCHES THE ROOF DRAIN WITH A FLAME</b>	1	2	3
<b>Field mock-up stations 3 and 4: installing field membrane over drain</b>			
wears proper PPE	1	2	3
stops advancing roll before reaching drain	1	2	3
rolls membrane over drain without heating; marks and cuts drain opening	1	2	3
pulls roll back to expose bottom of membrane	1	2	3
evenly heats membrane without damaging substrate	1	2	3
lifts roll and flops the heated membrane over drain and into place	1	2	3
immediately steps membrane into place and trowels around drain and lapped seam	1	2	3
<b>NEVER TOUCHES THE ROOF DRAIN WITH A FLAME</b>	1	2	3
<b>Field mock-up stations 3 and 4: installing field membrane around pipe penetration</b>			
wears proper PPE	1	2	3
stops advancing roll before reaching pipe	1	2	3
lifts and unrolls the roll backward, exposing underside of membrane far enough to extend beyond pipe	1	2	3
pulls the extended membrane beyond penetration without heating and lays sheet up against pipe	1	2	3
cuts and dry-fits membrane tightly around pipe	1	2	3
pulls membrane roll backward and lays it upside down away from pipe	1	2	3
evenly heats the membrane without damaging the substrate	1	2	3
lifts roll and lays the membrane into place around pipe	1	2	3
immediately steps heated membrane into place and trowels lapped seams	1	2	3
<b>NEVER TOUCHES THE PIPE WITH A FLAME</b>	1	2	3
<b>Field mock-up stations 3 and 4: ending field membranes at roof edges and walls</b>			
wears proper PPE	1	2	3
stops heating the roll before reaching wall or edge	1	2	3
extends roll without heating to the wall or roof edge and cuts to length	1	2	3
pulls unheated membrane back to the point it is fully bonded to substrate	1	2	3
evenly heats the membrane without damaging the substrate; lifts heated membrane using a trowel; grips it and flops it into place	1	2	3
immediately steps heated membrane into place and trowels lapped seams	1	2	3
<b>NEVER TOUCHES THE WALL OR EDGE WITH A FLAME</b>	1	2	3
<b>Shutting off the torch</b>			
sets lit torch down on its stand away from propane cylinder	1	2	3
walks over to cylinder and closes the valve tightly	1	2	3
returns to torch and squeezes trigger to burn out remaining gas from hoses and regulator	1	2	3
closes all torch valves	1	2	3
opens regulator adjusting valve	1	2	3



**Certified Roofing Torch Applicator Training Program**

**TRAINING EVALUATION FORM**

To evaluate the effectiveness of this training, we need your honest evaluation of the training you just received. The rating system is on a scale of 1 to 5 (5 being the highest).

Name of Trainer(s): \_\_\_\_\_ Date: \_\_\_\_\_

Training Session No.: \_\_\_\_\_

1. This session met my expectations.

Not at all					Very much
1	2	3	4	5	

How/How not?

2. The course material was presented well.

Not at all					Very much
1	2	3	4	5	

How/How not?

3. The session environment made it easy for me to fully participate.

Not at all					Very much
1	2	3	4	5	

How/How not?

4. The handouts and visual aids were helpful.

Not at all					Very much
1	2	3	4	5	

How/How not?

5. The hands-on training was organized well.

Not at all					Very much
1	2	3	4	5	

How/How not?

6. I understood the fire-preventing torching techniques taught during the hands-on training.

Not at all					Very much
1	2	3	4	5	

How/How not?

7. Rate the trainer’s effectiveness during the session.

	Low				High
Trainer (1):	1	2	3	4	5
Trainer (2):	1	2	3	4	5

8. Please rate your level of knowledge, skills and abilities in this subject area:

	Low				High
Before the session:	1	2	3	4	5
After the session:	1	2	3	4	5

9. Which sessions or aspects of the training were most helpful, and why?

10. Which sessions or aspects of the training were least helpful, and why?

11. Would you recommend this workshop to others?

(Circle one.) Yes      No

Why or why not?

Other comments:

**Thanks! We appreciate your feedback.**

**Please mail this form within 10 days to:**

**NRCA  
10255 W. Higgins Road, Suite 600  
Rosemont, IL 60018-5607  
Attention: Education Department**